

## SOLAR LIGHTING

# SRGLS

## LED Solar Runway Guard Light System



### Compliance with Standards

CE: Complies with the requirements of the EMC Directive 2004/108/EC

### Uses

- Runway Guard Light (RGL)
- Runway Incursion Prevention

ADB's LED Solar Runway Guard Light System (SRGLS) is an ideal choice for an airfield that requires improved safety measures, but experiences difficulties with grid access. ADB's SRGLS consists of an elevated unidirectional flashing yellow Solar-powered Runway Guard Light (SRGL) and a Solar Engine Power Supply (SEPS). The SRGLS provides a distinctive warning to pilots that they are approaching a runway holding position and are about to enter an active runway. The SEPS incorporates the latest technology in solar technology, hardware and software to provide power and control to the SRGL. See data sheet 3082 for more information about the SEPS.

The SRGLS is typically installed in pairs, one on either side of the taxiway holding position. The SRGLS can also be used in combination with L-852G (In-pavement Runway Guard Light), L-852S (In-pavement Stop Bar Light), and L-862S (Elevated Stop Bar Light) to provide additional safety under low-visibility conditions on the airfield.

### Features

- ADB's Solar Runway Guard Light System (SRGLS) can provide 24-hour unidirectional flashing to aid in reducing airfield incursions at unmarked runway and taxiway intersections.
- The SRGLS installs in minutes with no trenching, cabling, or external power, and can be relocated just as quickly.
- Includes lamps, frangible column, and tether.
- Fixture is controlled (flash-rate) from an intelligent lighting control system module located in the SEPS.
- Unprecedented reliability: microprocessor Energy Management System (EMS) monitors and adapts the brightness to environmental conditions for consistent operation and long life under the toughest conditions.
- Battery daily depth of discharge is sized for a minimum of five years of service.
- The minimum autonomy or operational period without charging is seven days.
- Protect personnel and assets: Optional hand-held wireless control allows for remote operation of an SRGL including mode changes for enhanced visibility in poor weather conditions.
- Green solution: a clean, renewable and reliable energy source with the lightest environmental footprint.

### SRGLS Ordering Code<sup>1</sup>

44A4744-

#### Power

5 = Solar Engine Power Supply (SEPS)

#### Monitoring

3 = No monitoring

#### LED Color

5 = Traffic Signal Yellow

#### Photocell Feature

3 = Without photocell

#### Notes

<sup>1</sup> SRGLS should only be powered with a SEPS. For more information and to order a SEPS, see data sheet 3082.

### Features (Continued)

- The SRGL can be aimed both vertically and horizontally and has an Adjustable Light Beam: 0° to 20° vertically; ±20° horizontally.
- Average LED life of 56,000 hours under high-intensity conditions and more than 100,000 hours under actual operating conditions, resulting in significant reduction or even elimination of ongoing maintenance costs and periodic re-lamping expenses.
- The two SRGL light sources are surrounded by a black face plate and independent visors to reduce the amount of incident sunlight, thereby maximizing the contrast during the lamp ON/OFF cycle.
- LED lamp replacement is achieved without tools to minimize downtime.
- Access to the SRGL interface is achieved through a hinged waterproof lid that permits easy connection.
- Fixture is fabricated from corrosion-resistant materials, and all exterior surfaces are painted aviation yellow for added protection and visibility.
- High-strength 1832RGL base plate
- Flash Rate: Alternating flashes, 45-50 per minute

### Operating Conditions

Temperature: -40 °F to +131 °F (-40 °C to +55 °C)

Humidity: 0 to 100%

Wind: Withstands wind velocities up to 300 mph (480 kph)

**Benefits**

- Easy Installation: no specialized work crews required; limited air traffic disruption and functions immediately upon installation
- Compact, self-contained design; easy deployment and relocation
- Significant cost savings: no fuel or electrical bills
- Reduced maintenance cycles: no scheduled maintenance for up to five years
- Clean, renewable solution: a visible move towards eco-friendly practices

**Installation**

The Runway Guard Light should be installed according to FAA AC 150/5340-30.

The Solar Engine Power Supply (SEPS) has to be installed on a level concrete pad within 20 feet of the SRGL. For below ground wiring, L-867B base cans need to be installed under each SRGL and SEPS. Concrete pad installation requires two frangible couplings and two floor flanges to be ordered separately from the SEPS unit (Part No. 94A0581).

For a temporary application, the wiring between the SEPS and the SRGL can be above ground. Both the SRGL and SEPS contain side conduits for cabling access.

**SRGL Spare Components**

| Description                                     | Part No.  |
|---|-----------|
| Base plate, L-867B heavy-duty                   | 1832RGL   |
| Canopy, FAA                                     | 60A2408   |
| Canopy brackets                                 | 60A2410   |
| Frangible coupling and mtg flange kit, 11.5 TPI | 94A0581   |
| Lamp Assy Yellow                                | 94A0586-1 |
| Lamp Reflector Right                            | 62A2205-1 |
| Lamp Reflector Left                             | 62A2205-2 |
| Adjustable Draw Latch                           | 61A0271   |
| Tether  | 94A0054   |
| Terminal Strip                                  | 72A0391   |
| Compression Fitting                             | 77A0147   |
| Pipe Plug                                       | 77A0098   |

**SRGL Packaging**

|                   |   |
|-------------------|---|
| In cardboard box: | 30 x 22 x 17 in<br>(37.5 x 27.5 x 21.25 cm) |
| Net weight:       | 37 lb (16.8 kg)                             |

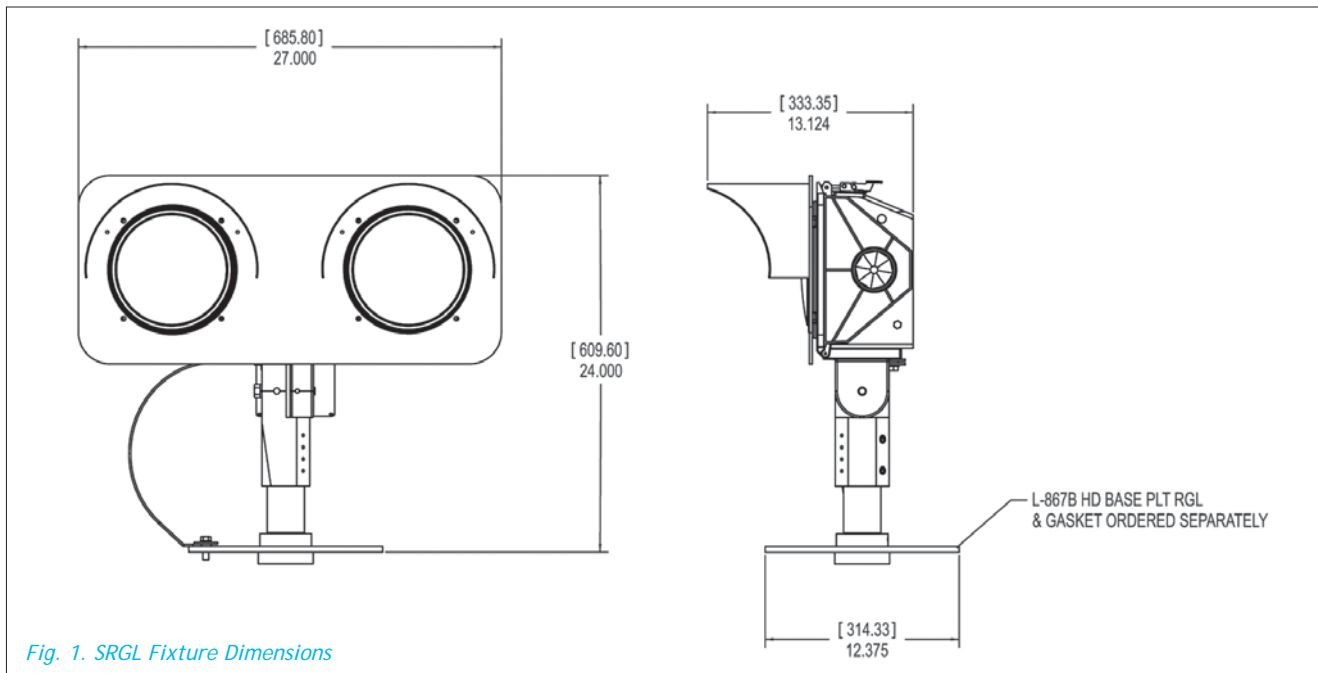

Product specifications may be subject to change, and specifications listed here are not binding. Confirm current specifications at time of order.

ADB Airfield Solutions  
Leuvensesteenweg 585  
B-1930 Zaventem  
Belgium

ADB Airfield Solutions, LLC  
977 Gahanna Parkway  
Columbus, OH 43230  
USA

© ADB Airfield Solutions  
All rights reserved

Telephone: +32 (0)2 722.17.11  
www.adb-air.com

Telephone: +1 614.861.1304  
+1 800.545.4157