Hali-Brite®

Installation and Maintenance Manual

L-807, L807(L), L-806 and L-806(L) Wind Cones

Hali-Brite® Inc.
P.O. Box 10
Crosby, MN 56441

Tel: 800.553.6269
Fax: 218.546.6854
www.halibrite.com

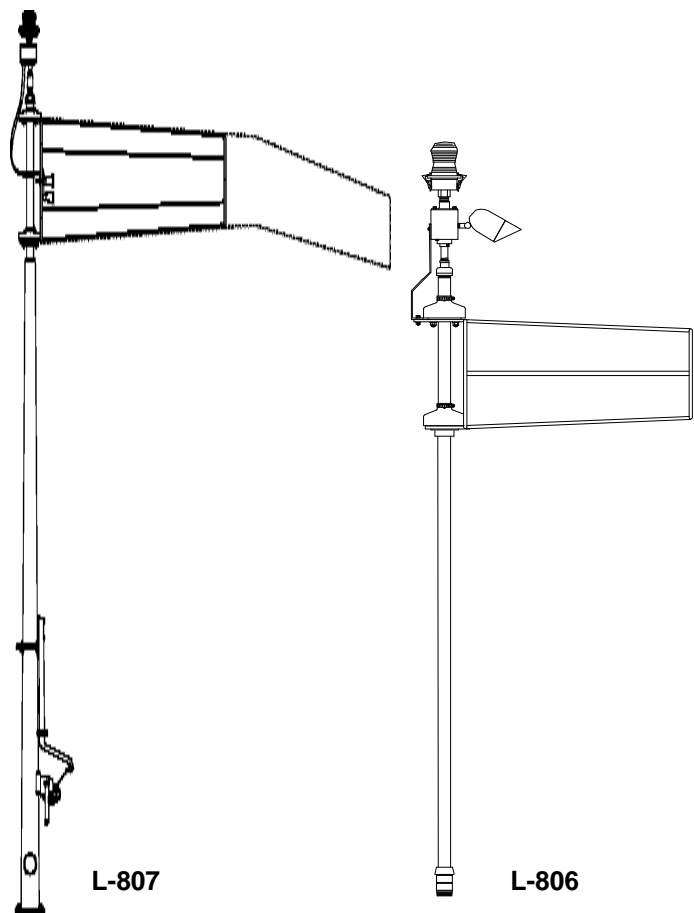

Table of Contents

CHAPTER 1

Introduction

About This Manual	4
Model Configurations	4
Reference Material	5
Warranty	5
Disclaimers	6

CHAPTER 2

Safety Precautions

Safety Statements	7
General Practices	8
Electrical Practices	9
Qualified Personnel	9
Proper Usage	10

CHAPTER 3

Specifications

Electrical Specifications	11
Physical Specifications	11

CHAPTER 4

Getting Started

Shipping and Unpacking	14
Taking Inventory	15
Tools and Supplies Needed	17

CHAPTER 5

Installing the L-807 Wind Cone

Installing the L-807 Wind Cone Anchor19
Positioning the Swing Arm22
Placing the Base of the Pole onto the Anchor22
Attaching the Basket to the Pole24
Installing Lights25
 Installing the External Lighting Kit25
 Installing the Internal Lighting Kit27
Wiring the Lights to the Power Source28
Installing the Wind Sock to the Basket29
Raising the Top Half of the Pole29

CHAPTER 6

Installing the L-806 Wind Cone

Installing Lights31
 Installing the External Lighting Kit32
 Installing the Internal Lighting Kit33
Installing the Wind Sock to the Basket34
Assembling the Pole to the Baseplate35
Wiring the Lights to the Power Source35
Attach the Pole Assembly to the Base Can36

CHAPTER 7

Maintaining and Servicing the Wind Cones

Tools Required37
Lowering the Top of the L-807 Pole37
Inspecting Wind Cone Components38
Replacing Lamps39
Replacing an Internal Floodlight Lamp40
Replacing an External Floodlight Lamp40
Replacing an Obstruction Lamp41

CHAPTER 8

Spare Parts

How to Order Parts42
Recommended Spare Parts42

CHAPTER 9

Wiring Diagrams

CHAPTER 1

Introduction

About This Manual

The information in this manual is provided to assist installation and maintenance personnel in the proper installation, upkeep, and maintenance of the L-806, L-806(L), L-807 and L-807(L) Wind Cones. The (L) suffix denotes models with LED lamps. This manual also includes installation and maintenance instructions for all equipment sold as options to the basic unit.

Model Configurations

This manual covers the models listed below:

TABLE 1. Wind Cone Models

L-807 and L-807(L) Models	L-806 and L-806(L) Models
L807-S1-UN-NON-ON-N	L806-S1-UN-NON-ON-N
L807-S1-EX-120-ON-5	L806-S1-EX-120-ON-5
L807-S1-EX-230-ON-5	L806-S1-EX-230-ON-5
L807-S1-EX-66A-ON-5	L806-S1-EX-66A-ON-5
L807-S1-IN-120-ON-5	L806-S1-IN-120-ON-5
L807-S1-IN-12-ON-5	L806-S1-IN-12-ON-5
L807-S1-EX-120-ON-N	L806-S1-EX-120-ON-N
L807-S1-IN-120-ON-N	L806-S1-IN-120-ON-N
L807-S1-EX-12-ON-5	L806-S1-EX-12-ON-5
L807-S1-IN-66A-ON-5	L806-S1-IN-66A-ON-5
L807-S2-UN-NON-ON-N	
L807-S2-IN-120-ON-5	
L807-S2-IN-12-ON-5	
L807-S2-EX-120-ON-5	
L807-S2-EX-230-ON-5	
L807-S2-EX-66A-ON-5	
L807-S2-EX-120-ON-N	
L807-S2-IN-120-ON-N	
L807-S2-EX-12-ON-5	
L807-S2-IN-66A-ON-3	

Reference Material

- Store this manual or any reference material within easy reach of personnel installing, operating, maintaining, or repairing this equipment.
- Refer to the FAA Advisory Circular AC 150/5340-26, Maintenance of Airport Visual Aids Facilities, for instructions on safety precautions.

Warranty

Hali-Brite® products are guaranteed against mechanical, electrical, and physical defects (excluding lamps) for a period of one year from the date of installation or a maximum of two years from the date of shipment and are guaranteed to be merchantable and fit for the ordinary purposes for which such products are made. In addition, Hali-Brite® products which are FAA certified to Engineering Brief 67D shall have a four year warranty, from date of installation, on the LED lamp(s) and the associated power supply. Hali-Brite® will correct by repair or replacement, at its option, equipment or parts which fail because of mechanical, electrical or physical defects, provided that the goods have been properly handled and stored prior to installation, properly installed and properly operated after installation, and provided further that Buyer gives Hali-Brite® written notice of such defects after delivery of the goods to Buyer. Hali-Brite® reserves the right to examine goods upon which a claim is made. Said goods must be presented in the same condition as when the defect therein was discovered. Hali-Brite® further reserves the right to require the return of such goods to establish any claim. Hali-Brite's obligation under this guarantee is limited to making repair or replacement within a reasonable time after receipt of such written notice and does not include any other costs such as the cost of removal of defective part, installation of repaired product, labor or consequential damages of any kind, the exclusive remedy being to require such new parts to be furnished. Hali-Brite's liability under no circumstances will exceed the contract price of goods claimed to be defective. Any returns under this guarantee are to be on a transportation charges prepaid basis. For products not manufactured by, but sold by Hali-Brite®, warranty is limited to that extended by the original manufacturer. This is Hali-Brite's sole guarantee and warranty with respect to the goods; there are no express warranties or warranties of fitness for any particular purpose or any implied warranties of fitness for any particular purpose or any implied warranties other than those made expressly herein. All such warranties are expressly disclaimed.

Details and values given in this manual are average values and have been compiled with care. They are not binding, however, and Hali-Brite® disclaims any liability for damages or detriments suffered as a result of reliance on the information given herein or the use of products, processes or equipment to which this manual refers. No warranty is made that the use of the information or of the products, processes or equipment to which this manual refers will not infringe any third party's patents or rights. The information given does not release the buyer from making their own experiments and tests.

Disclaimers

This manual is published for informational purposes only and the information provided should not be considered as all-inclusive or covering all contingencies. If further information is required, Hali-Brite Inc. should be contacted.

Sale of the product shown in this manual is subject to Hali-Brite's terms and conditions including, but not limited to, the Hali-Brite® Warranty. Such terms and conditions are available upon request.

Hali-Brite's warranty will not apply to any products which have been "so repaired or altered outside the manufacturer's plants as, in the manufacturer's judgment, to affect its reliability and performance."

No warranties, express or implied, including warranties of fitness for a particular purpose or merchantability, or warranties arising from course or dealing or usage of trade, are made regarding the information, recommendations, and descriptions contained herein. The manufacturer is not responsible and will not be held liable in contract or in tort (including negligence) for any special, indirect or consequential damages, including injury or damage caused to vehicles, contents or persons, by reason of the installation of any Hali-Brite® product or its mechanical or electrical failure.

CHAPTER 2

Safety Precautions

To help you install and maintain this equipment safely and efficiently make sure you read and understand all safety information in this manual prior to performing any procedure. Failure to do so may result in personal injury, property damage, or possible death.

Safety Statements

The following safety statements are used throughout this manual. They will alert you to possible safety hazards and conditions that could result in personal injury, death, or property and equipment damage.



CAUTION: Indicates hazards or unsafe practices which could result in minor personal injury, product, or property damage.



WARNING: Indicates hazards or unsafe practices which could result in severe personal injury or death.



DANGER: Indicates immediate hazards which will result in severe personal injury or death.

General Practices

Read and become familiar with the general safety instructions provided in this section of the manual before installing, operating, maintaining, or repairing this equipment.

- Do not attempt to assemble or install this equipment if it has been damaged from shipping.
- Do not attempt to install or maintain this equipment if you or the equipment is standing in water.
- Only qualified personnel should perform maintenance on this equipment.
- Always use proper tools (as mentioned in this manual) to perform installation and maintenance.
- Use caution when cranking the winch. Always crank slowly and grasp the handle securely.
- Use proper hand and eye protection as needed when installing or maintaining this equipment.
- Make sure you have adequate first aid supplies available when installing this equipment.
- Do not modify this equipment as this could create a safety hazard and void your Hali-Brite® warranty.
- Only use Hali-Brite® replacement parts.
- Read and carefully follow the instructions given throughout this manual for performing specific tasks and working with specific equipment.
- Follow all applicable safety procedures required by your company, industry standards, and government or other regulatory agencies.
- Make sure all equipment is rated and approved for the environment in which you are using it.
- Follow all instructions for installing components and accessories.
- Protect components from damage, wear, and harsh environment conditions.
- Allow ample room for maintenance, wiring accessibility, and cover removal.

Electrical Practices

- Do not attempt to make electrical connections with the power on.
- Disconnect and lock out electrical power before touching any electrical connections. Refer to FAA Advisory Circular AC 150/5340-26.
- Install all electrical connections to local code.
- Use only electrical wire of sufficient gauge and insulation to handle the rated current demand. All wiring must meet local codes.
- Route electrical wiring along a protected path. Make sure it will not be damaged by moving equipment.
- Protect equipment with safety devices as specified by applicable safety regulations.
- If safety devices must be removed for installation, install them immediately after the work is completed and check them for proper functioning.
- Always use rated electrical tools when performing electrical work.
- Always make sure electrical connections are tight.
- Make sure electrical covers are in place after installation.
- Do not touch hot lamps with bare hands.

Qualified Personnel

Qualified personnel are those that are trained and experienced with installing or maintaining Hali-Brite® equipment. Only qualified personnel should install or maintain Hali-Brite® equipment and auxiliary features.

No one should:

- Attempt to install or perform maintenance on this or any Hali-Brite® equipment if they are physically impaired or under the influence of alcohol or non prescription drugs.
- Maintain or install this equipment without correct training, supervision or experience in mechanical or electrical equipment.
- Attempt to maintain or install this equipment without the correct tools as specified in this manual.

Proper Usage

Always use this equipment as specified in this manual. Improper usage may result in serious personal injury, property damage, or possible death.

- Do not modify any equipment that has not been recommended by Hali-Brite®.
- Do not use any replacement parts that are not purchased from Hali-Brite®.
- Hali-Brite® cannot be responsible for injuries or damages resulting from non-standard, unintended applications of its equipment. This equipment is designed and intended only for the purpose described in this manual. Uses not described in this manual are considered unintended uses and may result in serious personal injury, death, or property damage.

CHAPTER 3

Specifications

Part Number	See Notes	FAA Size	FAA Style	Power Source	Lamp Type	VA	Watts	Weight (pounds)
L806-S1-UN-NON-ON-N		1	II Unlighted	none	None	0	0	45
L806-S1-EX-120-ON-5		1	I-A External	120 VAC	LED	15	14	58
L806-S1-EX-230-ON-5		1	I-A External	230 VAC	LED	15	14	58
L806-S1-EX-66A-ON-5	3	1	I-A External	6.6 AMP	LED	28	26	57
L806-S1-IN-120-ON-5		1	I-B Internal	120 VAC	LED	32	19	59
L806-S1-EX-120-ON-N		1	I-A External	120 VAC	Halogen	191	191	55
L806-S1-IN-120-ON-N	2	1	I-B Internal	120 VAC	Halogen	316	316	57
L806-S1-EX-12-ON-5		1	I-A External	12 VDC	LED	6	6	57
L806-S1-IN-12-ON-5	2	1	I-B Internal	12 VDC	LED	6	6	57
L806-S1-IN-66A-ON-5	3	1	I-B Internal	6.6 AMP	LED	41	37	57
L807-S1-UN-NON-ON-N		1	II Unlighted	None	None	0	0	187
L807-S1-EX-120-ON-5		1	I-A External	120 VAC	LED	15	14	198
L807-S1-EX-230-ON-5		1	I-A External	230 VAC	LED	15	14	198
L807-S1-EX-66A-ON-5	3	1	I-A External	6.6 AMP	LED	28	26	197
L807-S1-IN-120-ON-5		1	I-B Internal	120 VAC	LED	32	19	200
L807-S1-EX-120-ON-N		1	I-A External	120 VAC	Halogen	191	191	196
L807-S1-IN-120-ON-N	2	1	I-B Internal	120 VAC	Halogen	316	316	198
L807-S1-EX-12-ON-5		1	I-A External	12 VDC	LED	6	6	197
L807-S1-IN-12-ON-5	2	1	I-B Internal	12 VDC	LED	6	6	197
L807-S1-IN-66A-ON-5	3	1	I-B Internal	6.6 AMP	LED	41	37	198
L807-S2-UN-NON-ON-N		2	II Unlighted	None	None	0	0	199
L807-S2-IN-120-ON-5		2	I-B Internal	120 VAC	LED	60	32	212
L807-S2-EX-120-ON-5		2	I-A External	120 VAC	LED	22	21	210
L807-S2-EX-230-ON-5		2	I-A External	230 VAC	LED	22	21	210
L807-S2-EX-66A-ON-5	3	2	I-A External	6.6 AMP	LED	28	26	209
L807-S2-EX-120-ON-N		2	I-A External	120 VAC	Halogen	191	191	208
L807-S2-IN-120-ON-N		2	I-B Internal	120 VAC	Halogen	516	516	210
L807-S2-EX-12-ON-5		2	I-A External	12 VDC	LED	10	10	210
L807-S2-IN-12-ON-5	2	2	I-B Internal	12 VDC	LED	10	10	210
L807-S2-IN-66A-ON-3	4	2	I-B Internal	6.6 AMP	LED	57	53	210

Notes:

1. Power consumption specifications include the L-810 obstruction light
2. This FAA Style is not ETL certified
3. Requires 100 watt L-830 transformer, sold separately. Add 17 VA for transformer loss.
4. Requires 200 watt L-830 transformer, sold separately. Add 15 VA for transformer loss.

Additional Specifications:

1. Wind Sock
 - a. Size 1 dimensions: 18 inch throat diameter, 8 foot length
 - b. Size 2 dimensions: 36 inch throat diameter, 12 foot length
 - c. Color: International Orange
2. Pole Material: Steel tubing
3. Temperature Range: -55C to +55C (-67F to +131F)
4. Wind Indication
 - a. Indicates true direction when wind velocity exceeds 3 knots
 - b. Wind sock full extension when wind velocity exceeds 15 knots
5. Dimensions
 - a. Type L-806 and L-806(L): see Figure 2
 - b. Type L-807 and L-807(L): see Figure 1

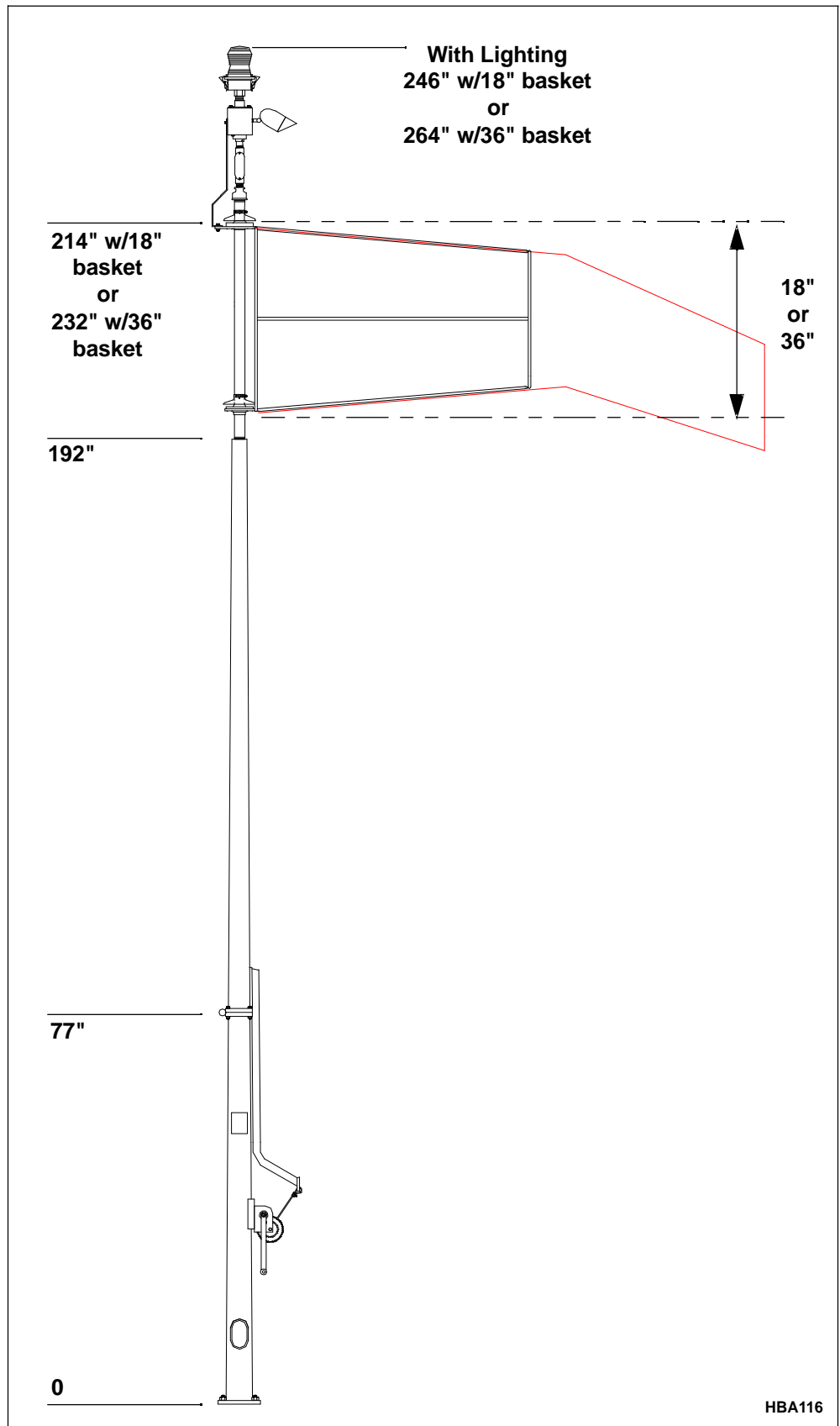

Figure 1. L-807 Dimensions

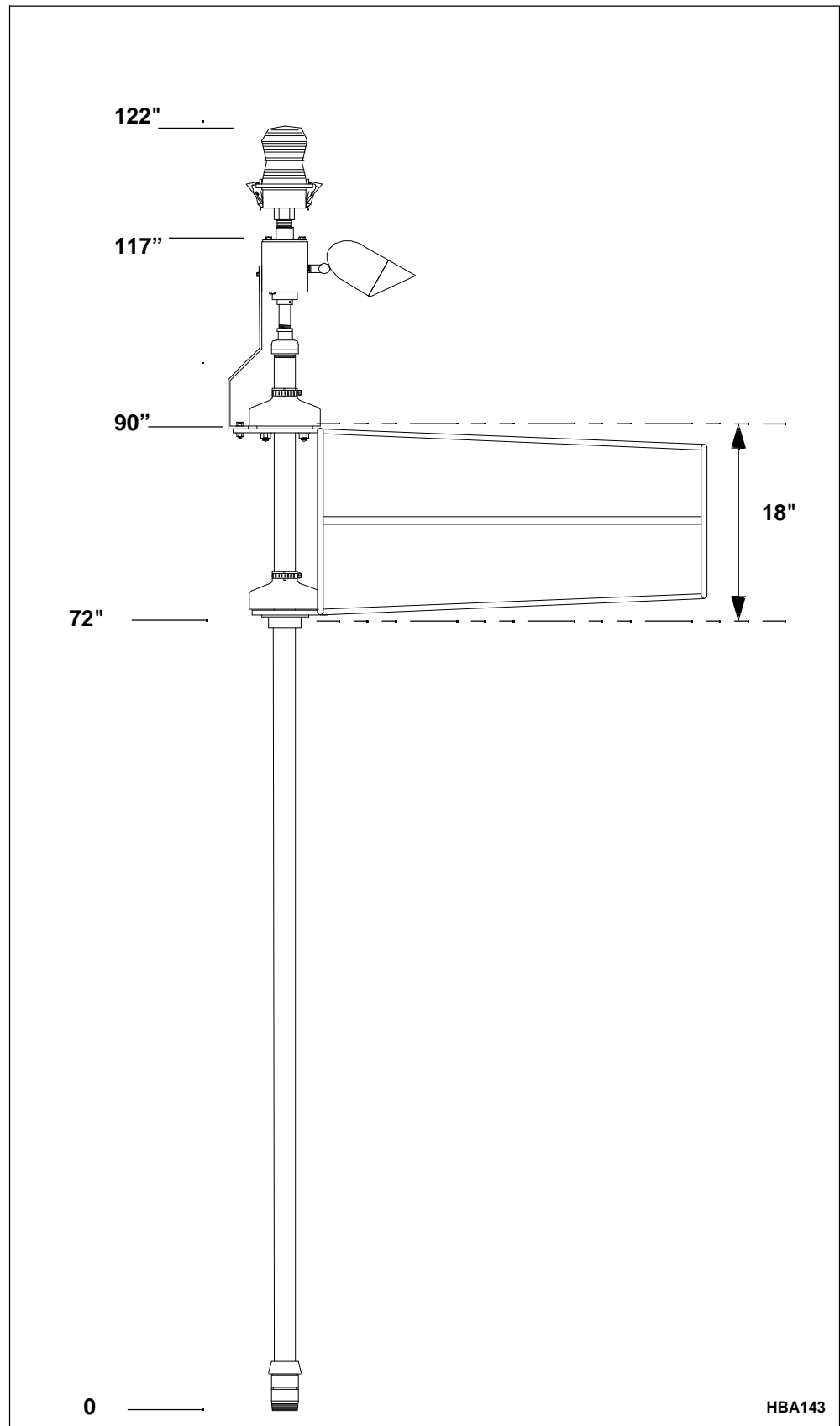

Figure 2. L-806 Dimensions

CHAPTER 4

Getting Started

Shipping and Unpacking

All components needed for assembly and installation of the L-807, L-807(L), L-806 and L-806(L) are shipped on a standard 10 ft pallet. If additional components or more than one unit is ordered the shipping pallet may be larger. All components are fastened to the shipping pallet, tools will be needed to unfasten these components prior to installation.

After unfastening all the components from the pallet inspect them for damage. If you find components that have been damaged from shipping please report them to the shipping company and file a claim.

NOTE: *You may want to photograph the damaged components in place on the shipping pallet. This will help you in placing a claim with the shipping company.*



CAUTION: *Some components are very heavy. Always use correct lifting practices when removing these components from the shipping pallet. If components are too heavy find additional help in removing these components.*

If excessive damage has occurred, not allowing assembly of the wind cone, contact Hali-Brite® for replacement parts.

Taking Inventory

Inventory all components prior to installation. Verify that you have everything required to assemble and install the L-807 or L-806 Wind Cone. If there are any missing components contact Hali-Brite®.



CAUTION: Always take care in handling individual components to prevent damage or injury.

The following components are standard or optional components shipped with an L-807 wind cone.

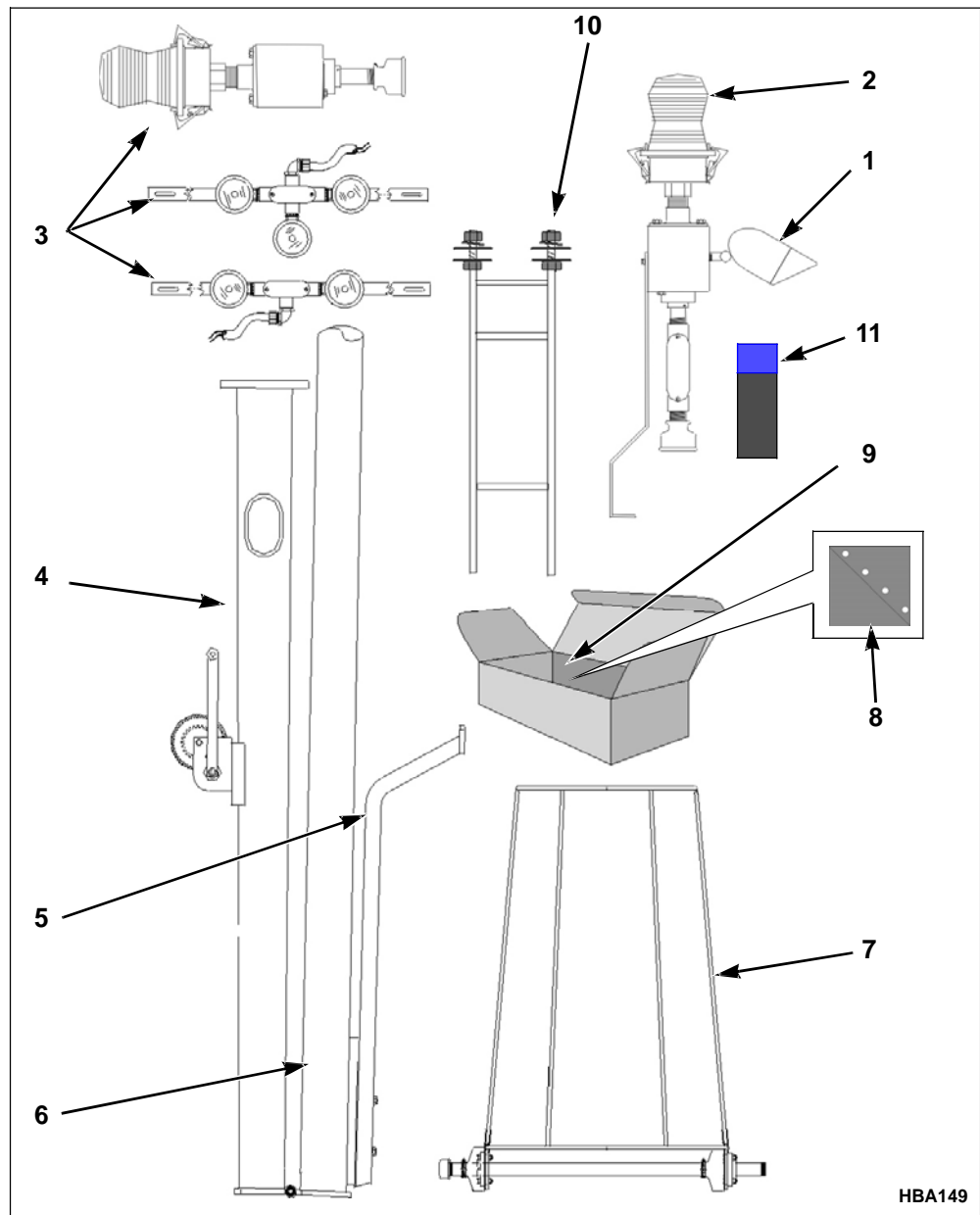

Figure 3. L-807 Wind Cone Components

HBA149

1.	Exterior Floodlights (optional)	8.	Wind Sock
2.	Obstruction Light	9.	Cable Straps (placed in box)
3.	Interior Floodlight Kit (optional)	10.	Anchor Bar with: 3/4" Lock Washers (4) 3/4" Flat Washers (8) 3/4" Nuts (8)
4.	Pole (bottom half)		
5.	Swing Arm		
6.	Pole (top half)		
7.	18" or 36" Basket	11.	Touch-Up Paint

The following components are standard or optional components shipped with an L-806 wind cone.

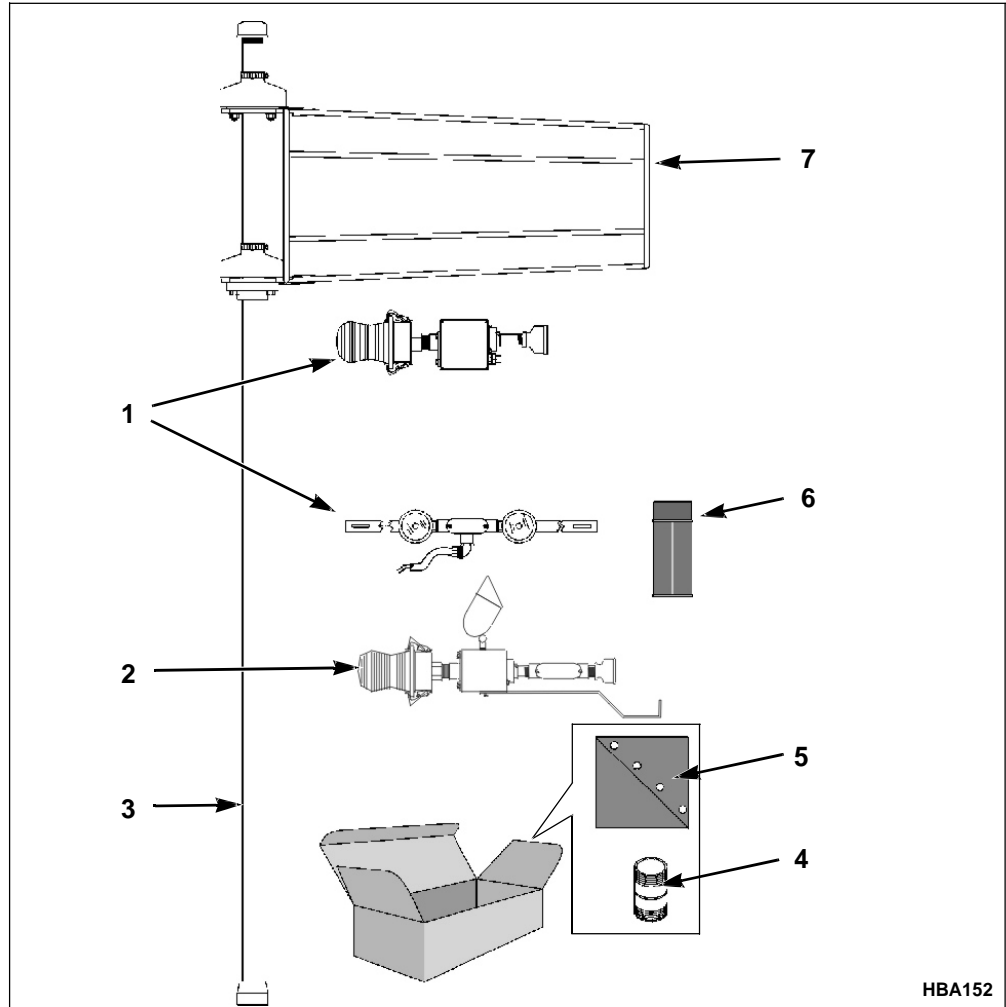
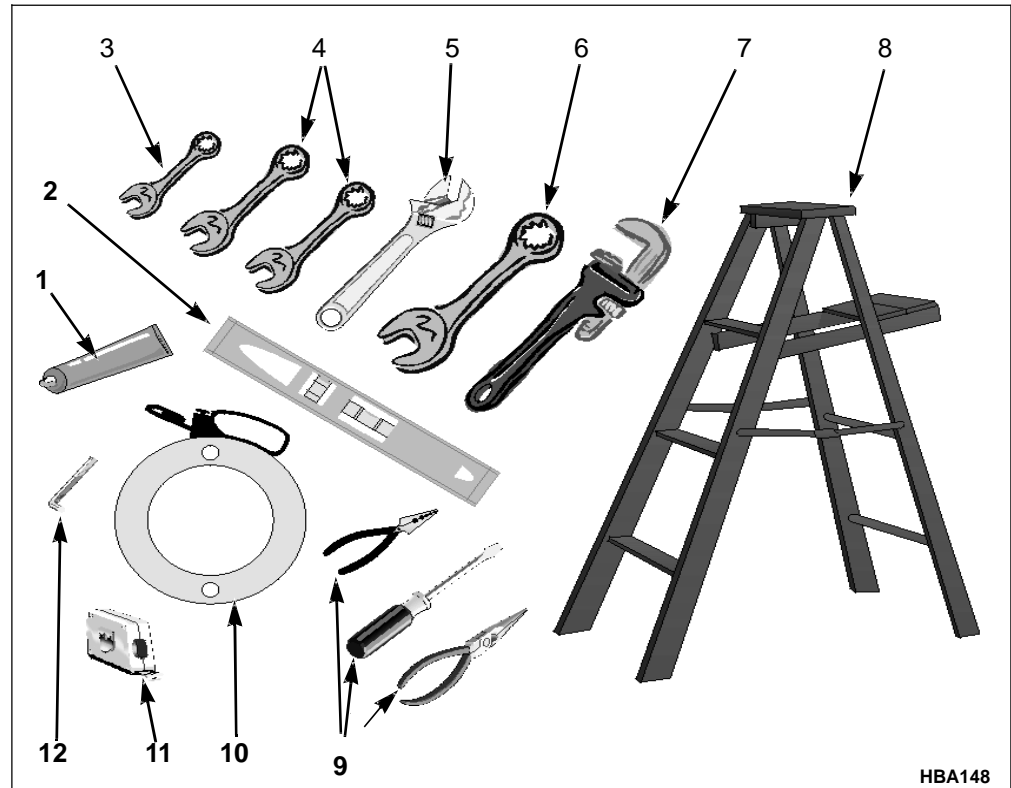

Figure 4. L-806 Wind Cone Components

1.	Interior Floodlight Kit consisting of: * Light pole assembly w/obstruction light * 2-light configuration (optional)	5.	Wind Sock
2.	Exterior Floodlights (optional)	6.	Touch-Up Paint
3.	Pole	7.	18" Basket
4.	Frangible Coupling		

Tools and Supplies Needed

After all components on the shipping pallet have been inventoried you will need to accumulate the following tools. These tools are required for assembling the L-807 or L-806 wind cone.



HBA148

Figure 5. Required Tools

1.	Anti-Locking Compound (Used to prevent threaded components from seizing)	7.	18" Pipe Wrench (Used to secure external light kit to the pole)
2.	12" or larger Carpenter Level (Used to level the anchor)	8.	6 ft Ladder (Used to access hinge on pole)
3.	9/16" Open End Wrench (Used to install the swing arm bolts)	9.	Electrician Tools (Used to wire lighting kit to power source)
4.	Two 5/8" Open End Wrenches (Used to secure the hinge bolts)	10.	50 ft Fishtape (Used to route lighting cable to base of pole)
5.	Large Crescent Wrench (Used to tighten nuts to the anchor bracket)	11.	Tape Measure (Used to set anchor height)
6.	1-1/16" Open End Wrench (Used to level the anchor nuts)	12.	3/16" Allen Hex Wrench (to remove electrical access cover plate)

CHAPTER 5

Installing the L-807 Wind Cone

In order to simplify the installation of the L-807 wind cone, the process can be broken down into the following subtasks. Perform them in the order they are listed below.

1. “Installing the L-807 Wind Cone Anchor” on page 19
2. “Positioning the Swing Arm” on page 22
3. “Placing the Base of the Pole onto the Anchor” on page 22
4. “Attaching the Basket to the Pole” on page 24 or
5. “Installing Lights” on page 25
6. “Wiring the Lights to the Power Source” on page 28
7. “Installing the Wind Sock to the Basket” on page 29
8. “Raising the Top Half of the Pole” on page 29

Installing the L-807 Wind Cone Anchor

The installation process begins with creating a firm base to which the pole assembly will be mounted. The installation contractor is responsible for the design of the base according to local codes and conditions. The following procedure is only provided as a general guideline for installing the anchor. You may have to modify this procedure to accommodate your location and conditions.

To install the anchor, perform the following steps.

1. Remove the anchor from the shipping pallet.
2. Remove the nuts and washers from each of the anchor's four threaded corner posts.
3. Acquire four 1/2" x 5 ft pieces of rebar.

NOTE: Rebar is not supplied by Hali-Brite®.

4. Use wire to tie each 5 ft piece of rebar to each of the four corner posts, see Item #6 in Figure 7 on page 21.
5. Dig a hole deep enough to accommodate the anchor and attached rebar legs. The hole should be approximately 7.5 ft deep.
6. Lower the anchor assembly into the hole.
7. Acquire a 1/2" piece of conduit approximately 4 ft long.

NOTE: Conduit is not supplied by Hali-Brite®.

8. Place a 90 degree bend approximately 20" from one end of the conduit, see Item #7 in Figure 7.
9. Place this end of the conduit between the four corner posts and 18" below grade. If possible wire the conduit in place, see Figure 7 on page 21.
10. Position the anchor assembly to ensure the anchor threads will protrude 4-5" above the grade of the finished concrete.
11. Fill the hole with concrete. Concrete specifications are to be determined by the installation contractor.
12. Use a carpenter level to level the anchor in all directions, see Figure 6. Check this several times as the concrete is curing.
13. After the concrete has cured, turn a 3/4" nut onto each of the four threaded corner posts. The nut must be turned down as far as it will go.
14. Place a level across two of the 3/4" nuts, see Item #2 in Figure 6. Raise or lower the nuts until they are level, in all directions. This ensures that the post will be level when placed onto the anchor.
15. Place a flat washer on top of each of the four 3/4" nuts, see Figure 6.

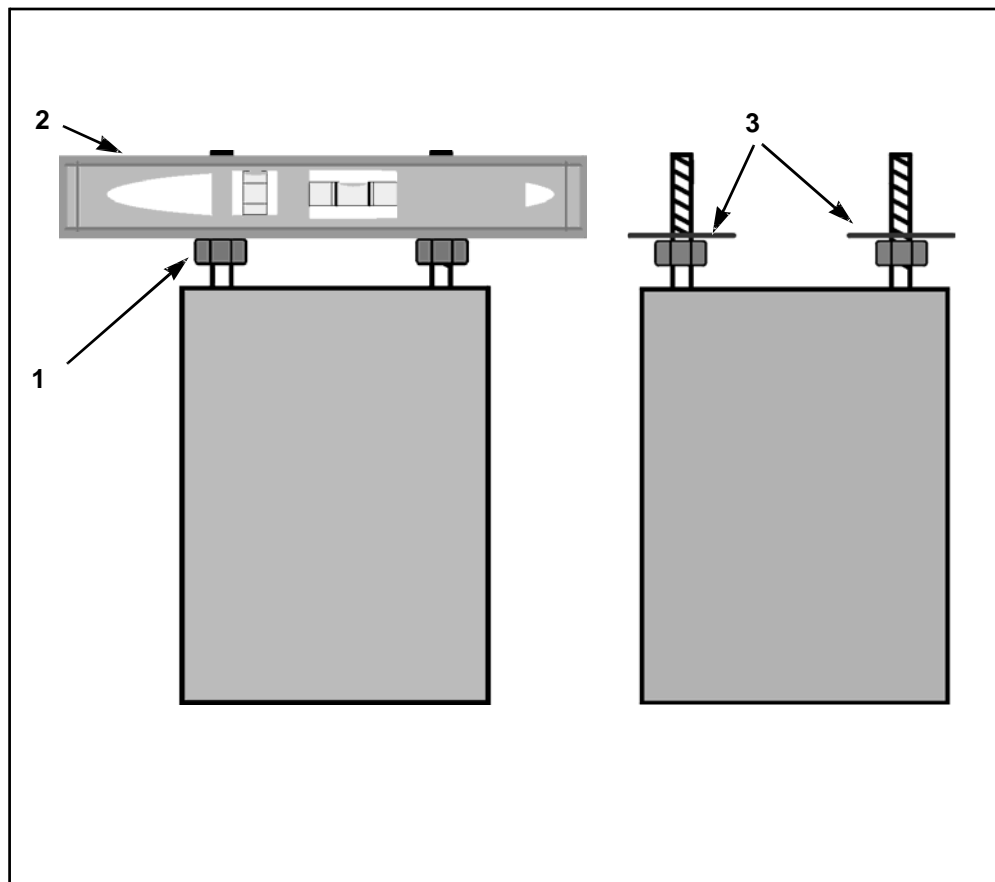
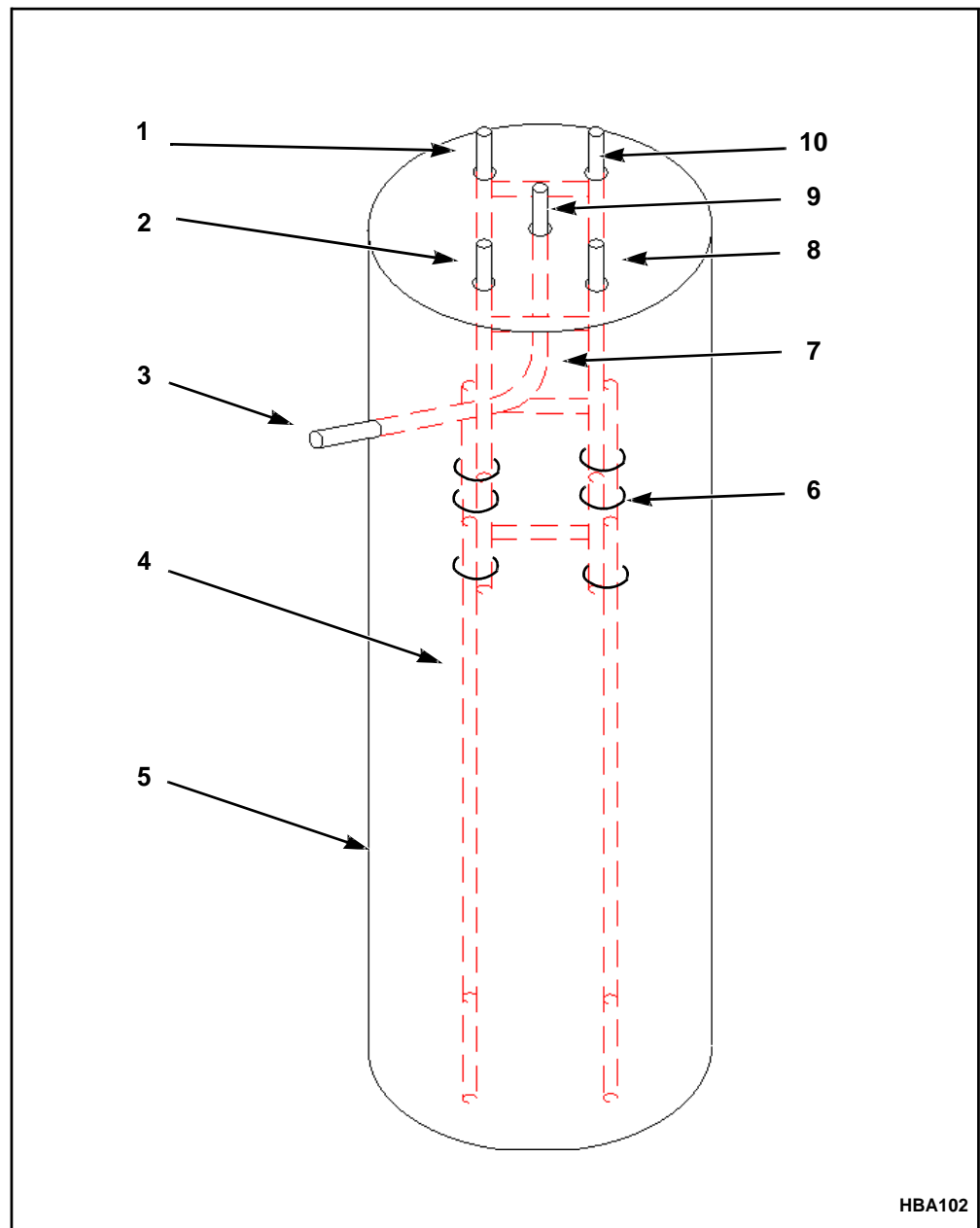

Figure 6. Leveling the Anchor Nuts for the L-807 Wind Cone

1.	3/4" Nut
2.	Carpenter Level
3.	3/4" Flat Washer



HBA102

Figure 7. L-807 Anchor Assembly

1.	Threaded corner post	6.	Wire ties
2.	Threaded corner post	7.	90 Degree bend in conduit
3.	1/2 in. conduit, 18" below grade	8.	Threaded corner post
4.	1/2 in. x 5 ft rebar legs wired to anchor	9.	1/2 inch conduit 2 inches above concrete
5.	Concrete Base 7.5 ft deep	10.	Threaded corner post

Positioning the Swing Arm

After installing the anchor, the swing arm must be correctly positioned. This is done by performing the following steps.

1. Using a 9/16" wrench, remove the bottom swing arm bolt and loosen the top swing arm bolt, see Figure 8.

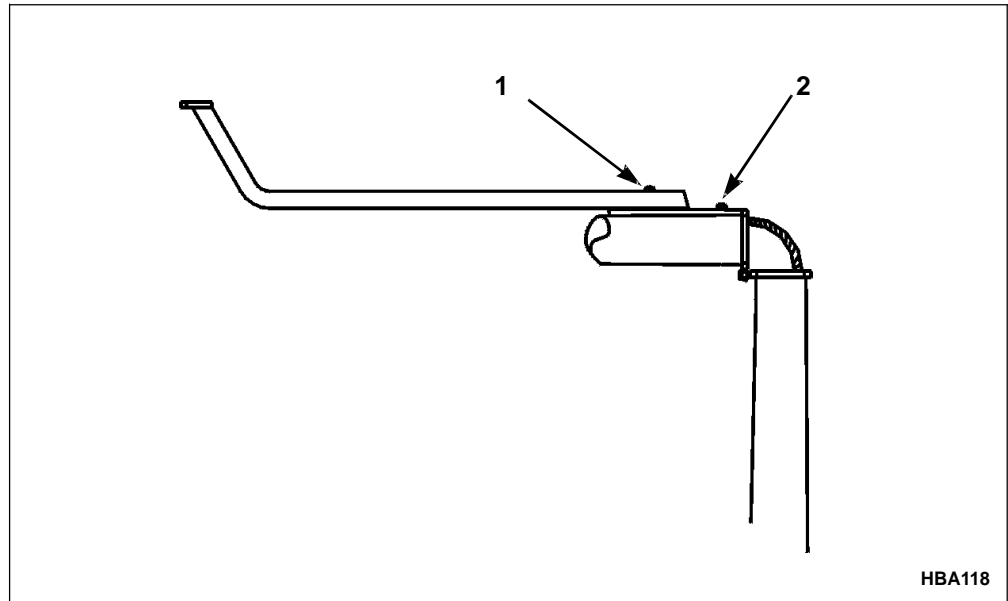

Figure 8. Positioning the Swing Arm

1.	Top Swing Arm Bolt
2.	Bottom Swing Arm Bolt

2. Rotate the swing arm to position as shown in Figure 9.
3. Place the bottom bolt back through the swing arm.
4. Tighten both swing arm bolts.
5. Place the base of the pole onto the anchor, see the following procedure.

Placing the Base of the Pole onto the Anchor

After the swing arm has been positioned, attach the pole to the anchor by performing the following steps.

1. Verify that the anchor has a 3/4" nut turned onto each of the anchor's four corner posts and that they have been leveled, see Figure 6. The four bottom nuts are used to level the pole. These nuts must be leveled prior to mounting the pole, see "Installing the L-807 Wind Cone Anchor" on page 19.

2. Verify that a flat washer has been placed on top of each 3/4" nut, see Figure 6.



CAUTION: *The following step requires two or more individuals. Use proper lifting techniques when raising or lowering heavy components.*

3. Position one person at the top half of the pole and one at the bottom half of the pole.
4. With both people lifting at the same time, lift the base of the pole over the top of the four corner posts, see Figure 9.
5. With the base of the pole on top of the four corner posts, place a 3/4" flat washer on top of each corner post, see Figure 9.
6. Place a 3/4" lock washer on top of each flat washer, see Figure 9.
7. Screw a 3/4" nut onto each corner post and tighten nuts using a 1-5/8" wrench until base of pole is secure, see Figure 9.

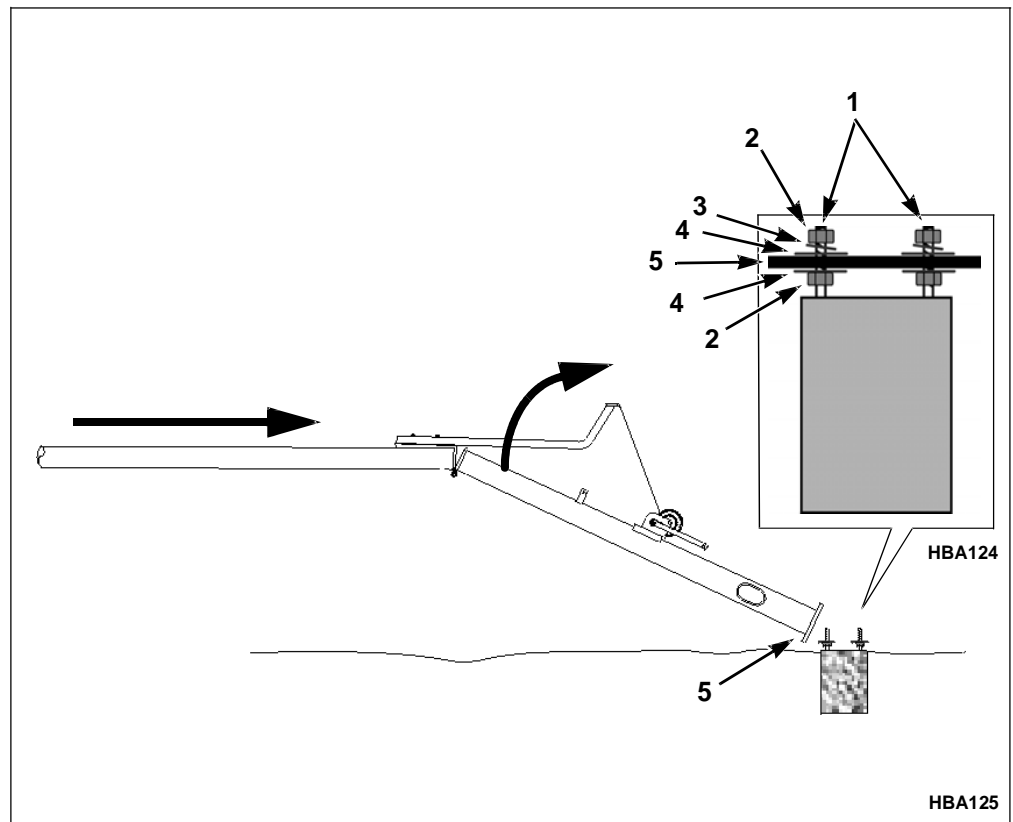

Figure 9. Fastening the Base to the Pole

1.	Threaded Corner Posts (4)	4.	3/4" Flat Washer (8)
2.	3/4" Nut (8)	5.	Base of Pole
3.	3/4" Lock Washer (4)		

8. Crank the top half of the pole to a comfortable working position.
9. Attach the basket to the pole, see the following procedure.

Attaching the Basket to the Pole

After the swing arm has been correctly positioned and the pole has been attached to the anchor, attach the basket to the pole.

1. Remove the basket from the shipping pallet.
2. Rotate the basket so the raincaps are pointed away from the pole, see Figure 10.

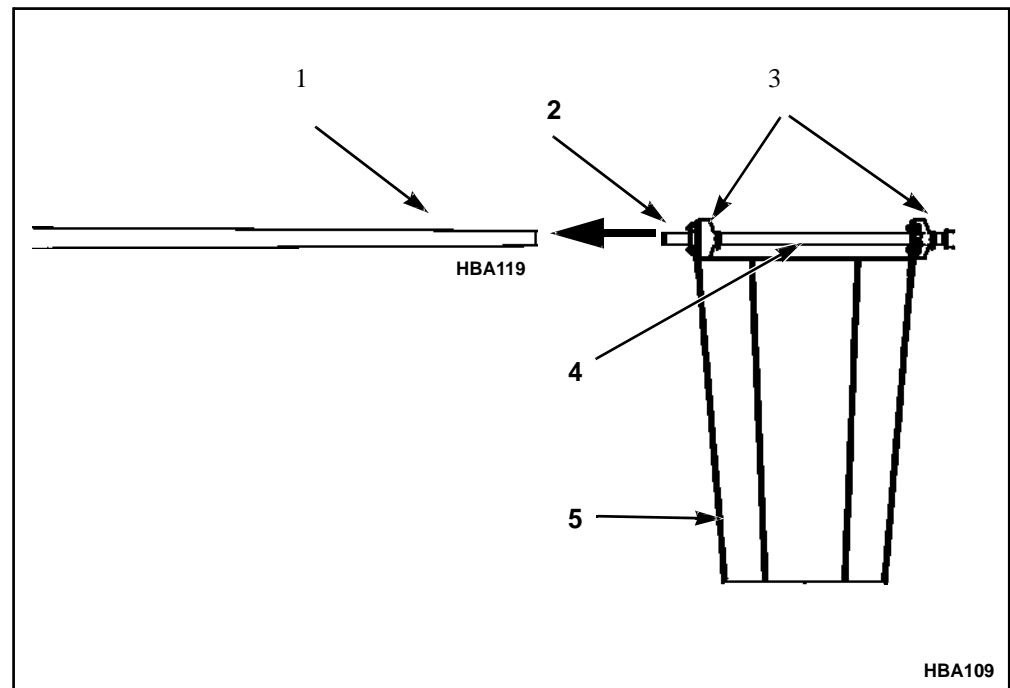

Figure 10. Positioning the Basket

1.	Top End of Pole
2.	Anti-locking Compound to Threads
3.	Rain Caps
4.	Basket Support Pipe
5.	Correctly Positioned Basket

3. Apply anti-locking compound to the threads of basket support pipe, see Figure 10.
4. Screw the basket to the top of the pole.
This is done by placing an 18" pipe wrench or larger around the basket support pipe. Tighten until secure.
5. Inspect the entire assembly for nicks or other damage to painted surfaces. Apply the supplied paint to these areas.
6. Attach the lights to the basket, see the following procedure "Installing Lights" on the following page. If the wind cone is unlighted, proceed to "Installing the Wind Sock to the Basket" on page 29.

Installing Lights

Perform one of the following:

- a. If external lights are required: continue with “Installing the External Lighting Kit” below.
- b. If internal lights are required: continue with “Installing the Internal Lighting Kit” on page 27.

Installing the External Lighting Kit

After the basket has been attached to the pole, you can install the external lighting kit. See Figure 12 for details.

1. Remove the access hole cover at the base of the pole, see Figure 12.
2. Push a fishtape into the access hole and up to the hinge at center of pole.
3. Insert the fishtape through the eyebolt welded to the inside of the upper pole.
4. Push the fishtape wire through the eyebolt and then through the top half of the pole.
5. Remove the end of the fishtape from the top of the pole.
6. Remove the lighting kit from the pallet and place it on the ground near the top of the basket.
7. Remove cable straps, used for shipping, from the electrical cable.
8. Attach the ends of the wire cable to the end of the fishtape.

NOTE: This requires that you wrap the ends of the wire and fishtape with black electrical tape to prevent the wires from coming loose when pulling the cable down to the access hole.

9. Using the fishtape, pull the wire cable through the top of the pole, then the eyebolt, then the bottom of the pole and finally out the access hole, see Figure 12.
10. Disconnect the wire from the fishtape. Pull all excess cable out of the access hole.
11. Place anti-locking compound onto the threads at the top of the basket support pipe. Make sure all threads have been covered thoroughly.
12. Mount the lighting kit onto the basket support pipe using a pipe wrench.
13. Refer to Figure 11. Remove the bolt, flat washer and lock washer from the upper bracket attachment. Remove the nut, flat washer and lock washer from the lower bracket attachment. Place the light support bracket on the upper and lower bracket attachment points as shown in Figure 11, with the slotted end of the light support bracket towards the wind cone lamp. Reinstall the upper bracket bolt and washers and the lower bracket nut and washer, but only finger-tight.

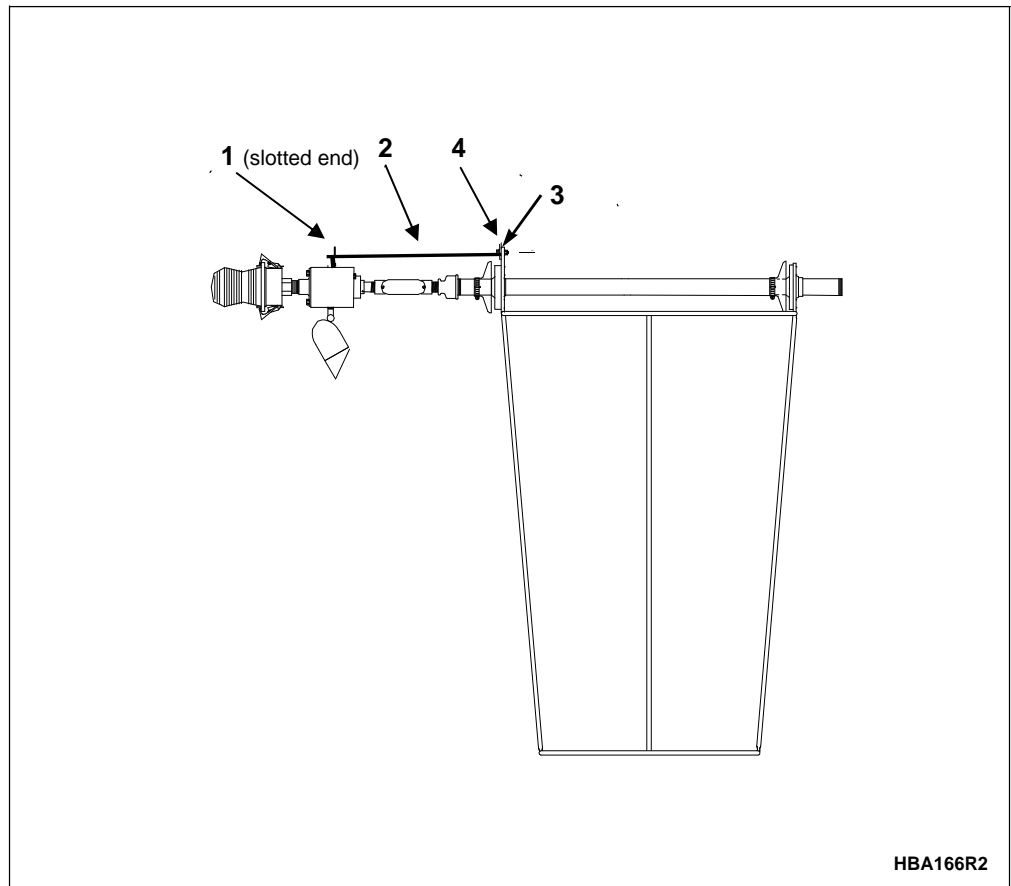
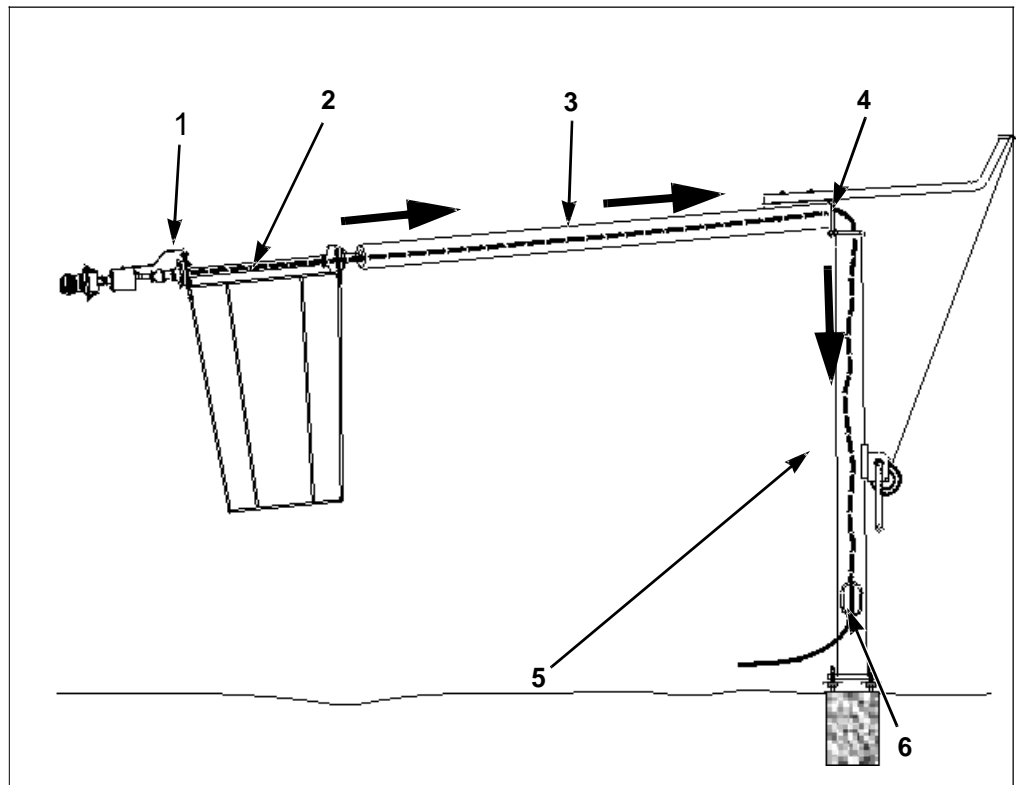

Figure 11. Installing the External Lighting Kit

1.	Upper Bracket Attachment
2.	Light Support Bracket
3.	Basket Bracket
4.	Lower Bracket Attachment

14. Tighten the fasteners on both ends of the light support bracket, see Figure 11.
15. Crank the top of the pole to its lowest position.
16. Wire and test the lights, see “Wiring the Lights to the Power Source” on page 28.
17. Install the wind sock, see “Installing the Wind Sock to the Basket” on page 29.



HBA163

Figure 12. Feeding the Electrical Cable

1.	Feed end of cable into top of basket support pipe
2.	Pull cable through basket support pipe
3.	Pull cable through top half of pole
4.	Pull cable through eyebolt
5.	Pull cable down through bottom half of pole
6.	Pull cable out access hole

Installing the Internal Lighting Kit

After the basket has been attached to the pole, install the internal lighting kit. This is done by performing the following steps.

1. Remove the internal lighting kit components from the shipping pallet.
2. Remove the two U-bolts from the lightbar, see Figure 13.
3. **NOTE: Place the lightbar across the center of the large end of the basket, see Figure 13. The floodlights must point into the basket. Position the bar horizontally, (parallel to the ground).**
4. Place the two U-bolts around the basket frame and back through the holes in the lightbar, see Figure 13.
5. Tighten the U-bolts to the basket frame.
6. Place anti-locking compound on the basket support pole threads.

7. Tighten the lighting kit to the basket support pipe.
8. Wire and test the lights, see “Wiring the Lights to the Power Source” on page 28.

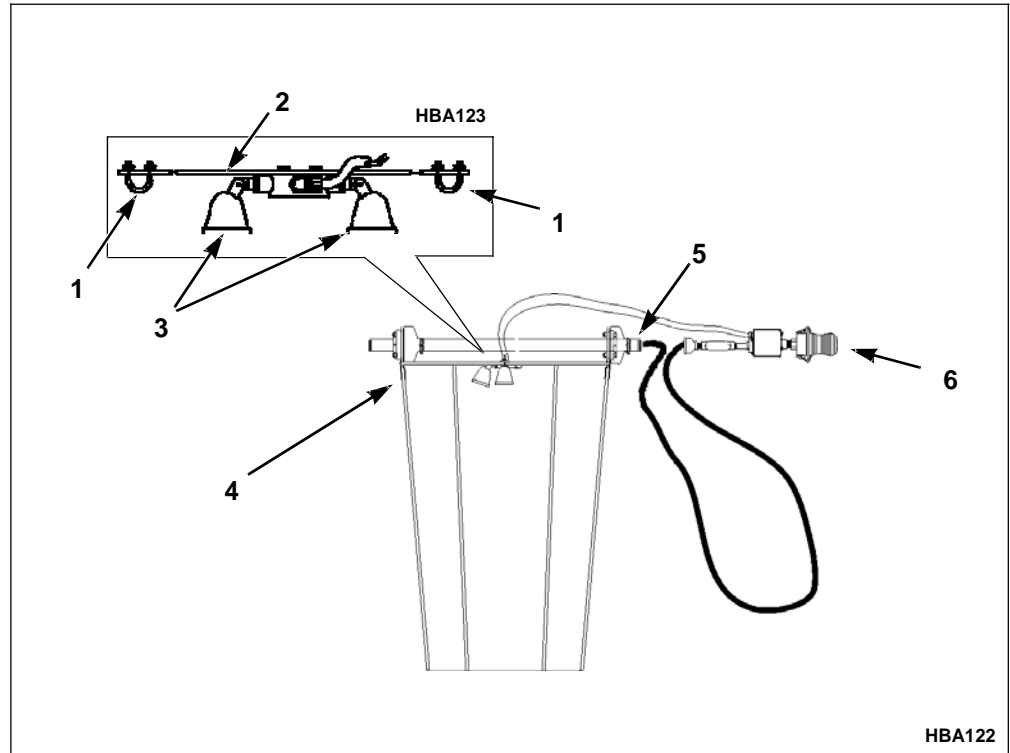

Figure 13. Installing the Internal Lighting Kit

1.	U-Bolts
2.	Lightbar
3.	Internal Floodlights
4.	Basket Frame
5.	Apply Anti-locking Compound
6.	Obstruction Light

Wiring the Lights to the Power Source

After the electrical cable has been pulled through the pole you can wire the lights to the power source and test them. See “Wiring Diagrams” on page 43.

NOTE: *Attach a suitable earth ground to the grounding lug located inside the pole access cover.*

If all lights illuminate and appear to be in working order you can then install the wind sock, see “Installing the Wind Sock to the Basket” on page 29.

Installing the Wind Sock to the Basket

After the basket has been attached to the top of the pole and any optional lighting kits installed, you can install the wind sock by performing the following steps.

1. Remove the wind sock from the shipping pallet.
2. One end of the sock has eyelets, open this end and slide the sock over the small end of the basket, see Figure 14.
3. Slide the sock over the basket until the entire basket is covered, see Figure 14.
4. Locate the group of cable straps on the shipping pallet.
5. Place a cable strap through each eyelet and around the basket frame.
6. Tighten each cable strap and clip off any excess portion of each cable strap.

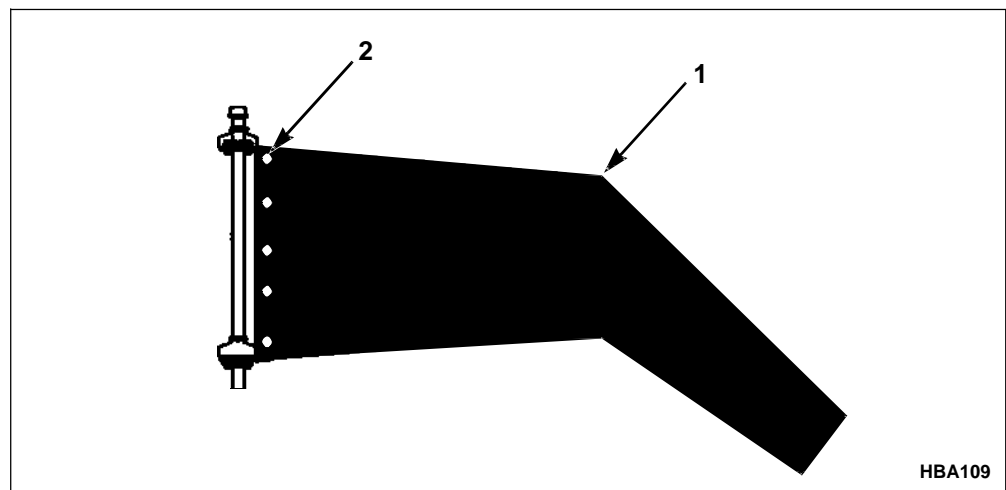

Figure 14. Installing the Wind Sock

1.	Wind Sock
2.	Eyelets

7. Raise the top half of the pole, see the following procedure.

Raising the Top Half of the Pole

After the wind sock has been installed, raise the top half of the pole into position.



CAUTION: Disconnect power going to the lights before raising the pole.

1. Using the handcrank on the winch, raise the pole until the hinge is closed, see Figure 15.

2. Place a bolt into each of the four holes in the hinge located at the center of the pole, see Figure 15.
3. Secure the four bolts and nuts.

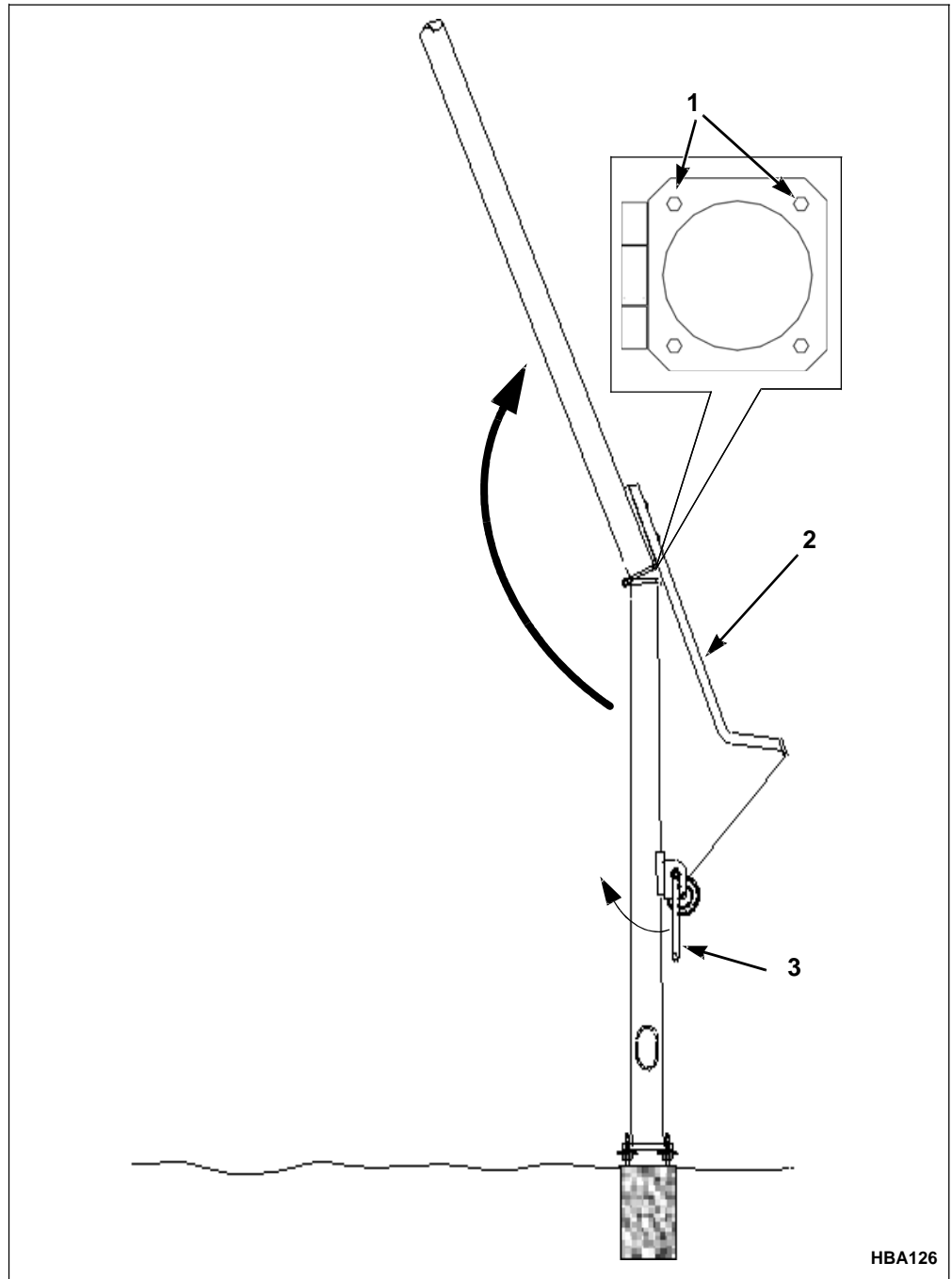

Figure 15. Raising the Top Half of the Pole

1.	7/16" Hinge Bolts (4)
2.	Swing Arm
3.	Winch Handle

CHAPTER 6

Installing the L-806 Wind Cone

In order to simplify the installation of the L-806 wind cone the process can be broken down into the following subtasks. Perform them in the order they are listed below.

1. “Installing Lights” on page 31
2. “Installing the Wind Sock to the Basket” on page 34
3. “Assembling the Pole to the Baseplate” on page 35
4. “Wiring the Lights to the Power Source” on page 35
5. “Attach the Pole Assembly to the Base Can” on page 36

Installing Lights

Perform one of the following:

- a. If no lights are required: continue with “Installing the Wind Sock to the Basket” on page 34.
- b. If external lights are required: continue with “Installing the External Lighting Kit” on page 32.
- c. If internal lights are required: continue with “Installing the Internal Lighting Kit” on page 33.

Installing the External Lighting Kit

Install the external lighting kit by performing the following steps.

1. Remove the external lighting kit from the pallet and place it on the ground near the top of the basket.
2. Remove cable straps, used for shipping, from the electrical cable.
3. Push the wire cable through the basket support pipe, down through the pole, and out the bottom, see Figure 16.
4. Place anti-locking compound onto the threads at the top of the basket support pipe, see Figure 16. Make sure all threads have been covered thoroughly.
5. Tighten the lighting kit onto the basket support pipe.
6. Refer to Figure 11. Remove the bolt, flat washer and lock washer from the upper bracket attachment. Remove the nut, flat washer and lock washer from the lower bracket attachment. Place the light support bracket on the upper and lower bracket attachment points as shown in Figure 11, with the slotted end of the light support bracket towards the wind cone lamp. Reinstall the upper bracket bolt and washers and the lower bracket nut and washer, but only finger-tight.
7. Tighten the fasteners on both ends of the light support bracket, see Figure 11.
8. Install the wind sock, see “Installing the Wind Sock to the Basket” on page 34.

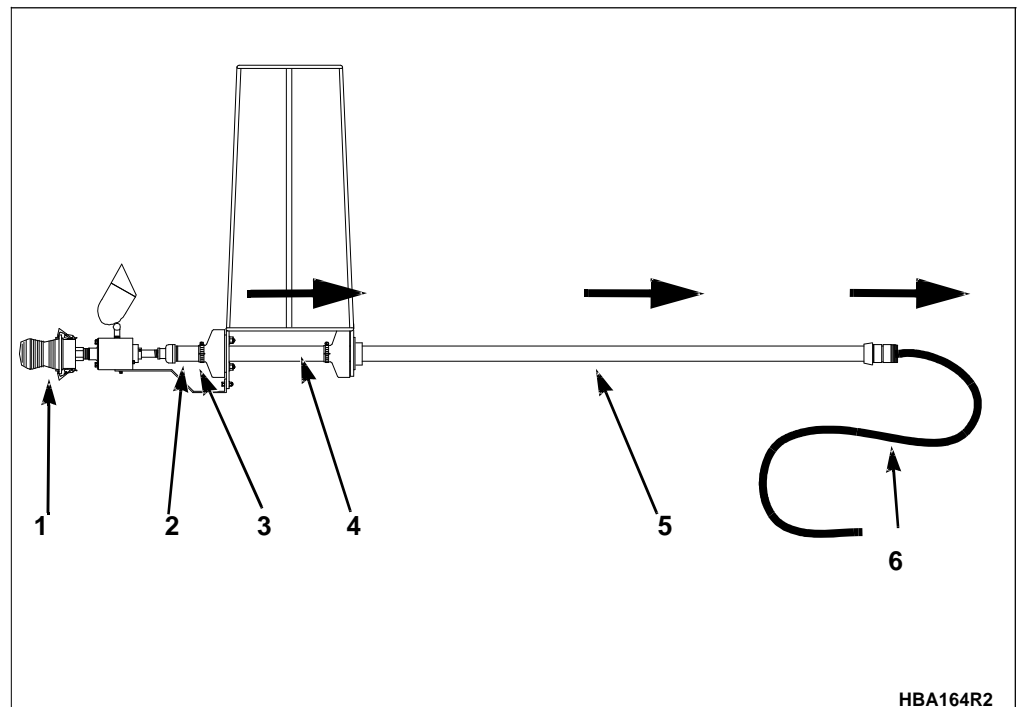

Figure 16. Feeding the Electrical Cable

1.	Place lights on ground
2.	Feed end of cable into top of basket support pipe
3.	Place anti-locking compound on threads
4.	Pull cable through basket support pipe
5.	Pull cable through pole
6.	Pull excess cable out bottom of pole

Installing the Internal Lighting Kit

Install the internal lighting kit by performing the following steps.

1. Remove the internal lighting kit from the shipping pallet.
2. Remove the two U-bolts from the light bar, see Figure 17.
3. **NOTE: Place the lightbar across the center of the large end of the basket, see Figure 17. The floodlights must point into the basket. Position the bar horizontally (parallel to the ground).**
4. Place the two U-bolts around the basket frame and back through the holes in the light bar, see Figure 17.
5. Tighten the U-bolts to the basket frame, see Figure 17.
6. Place anti-locking compound on the basket support pipe threads.
7. Screw the lighting kit to the basket support pipe.
8. Install the wind sock, see “Installing the Wind Sock to the Basket” on page 34.

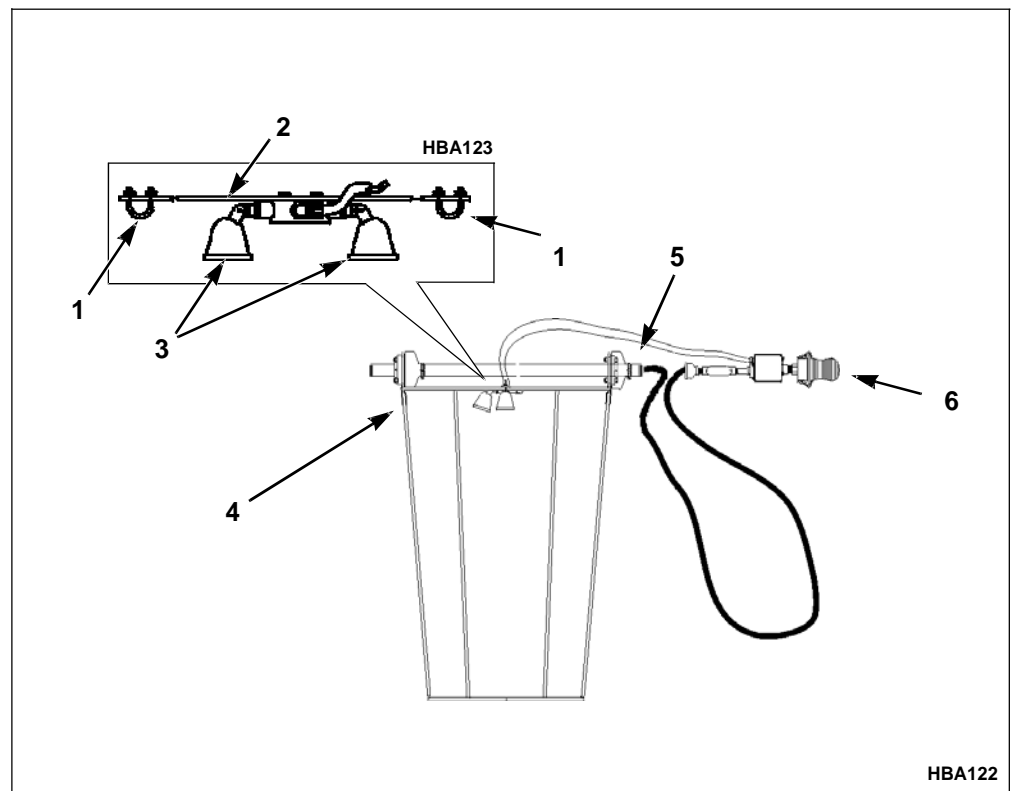

Figure 17. Installing the Internal Lighting Kit

1.	U-Bolts
2.	18" Light Bar
3.	Internal Floodlights
4.	Basket Frame
5.	Apply Anti-locking Compound
6.	Obstruction Light

Installing the Wind Sock to the Basket

After the basket has been attached to the top of the pole and any lighting kit installed, you can install the wind sock by performing the following steps.

1. Remove the wind sock from the shipping pallet.
2. One end of the sock has eyelets, open this end and slide the sock over the small end of the basket, see Figure 18.
3. Slide the sock over the basket until the entire basket is covered, see Figure 18.
4. Remove the group of cable straps from the shipping pallet.
5. Place a cable strap through each eyelet and around the basket frame.
6. Tighten each cable strap and clip off any excess portion of each cable strap.

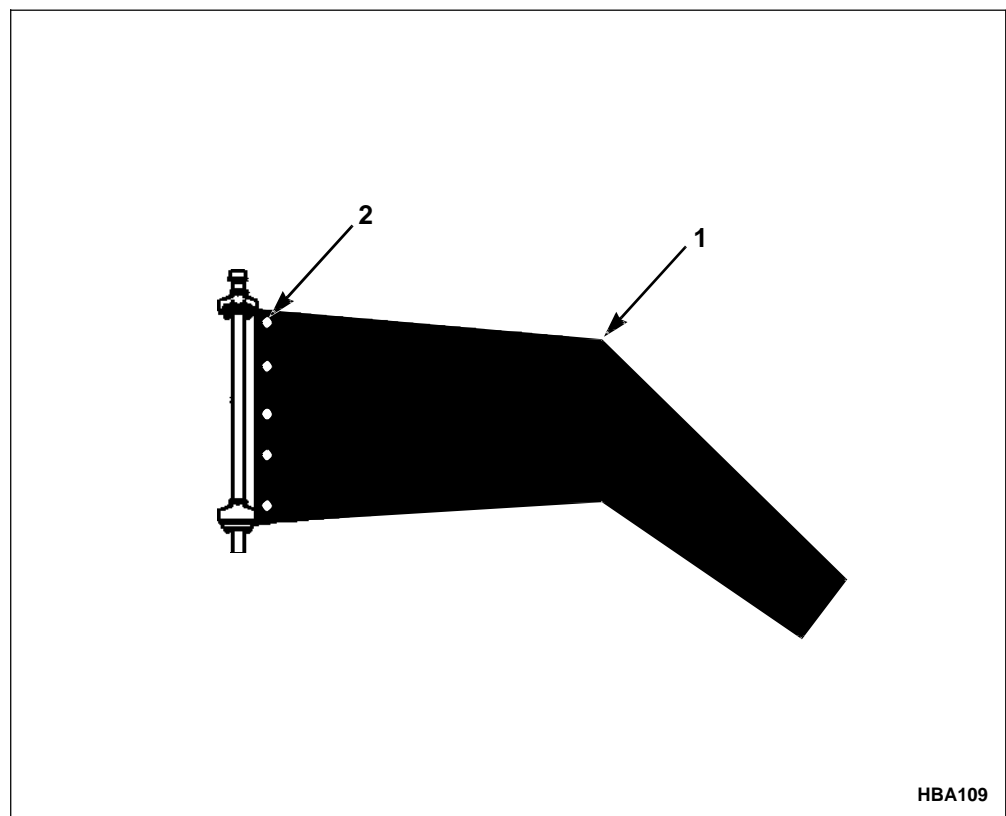

Figure 18. Installing the Wind Sock

1.	Wind Sock
2.	Eyelets

7. Inspect the entire assembly for nicks or other damage to painted surfaces. Apply the supplied paint to these areas.
8. Assemble the pole to the baseplate, see “Assembling the Pole to the Baseplate” on page 35.

Assembling the Pole to the Baseplate

Before the pole assembly can be erected you need to attach the pole and basket to the baseplate. This can be done by performing the following steps.

1. Remove the frangible coupling from the shipping pallet and screw it into the baseplate, see Figure 19.
2. Screw the pole assembly to the frangible coupling.
3. Wire the lights to the power source, see the following procedure.

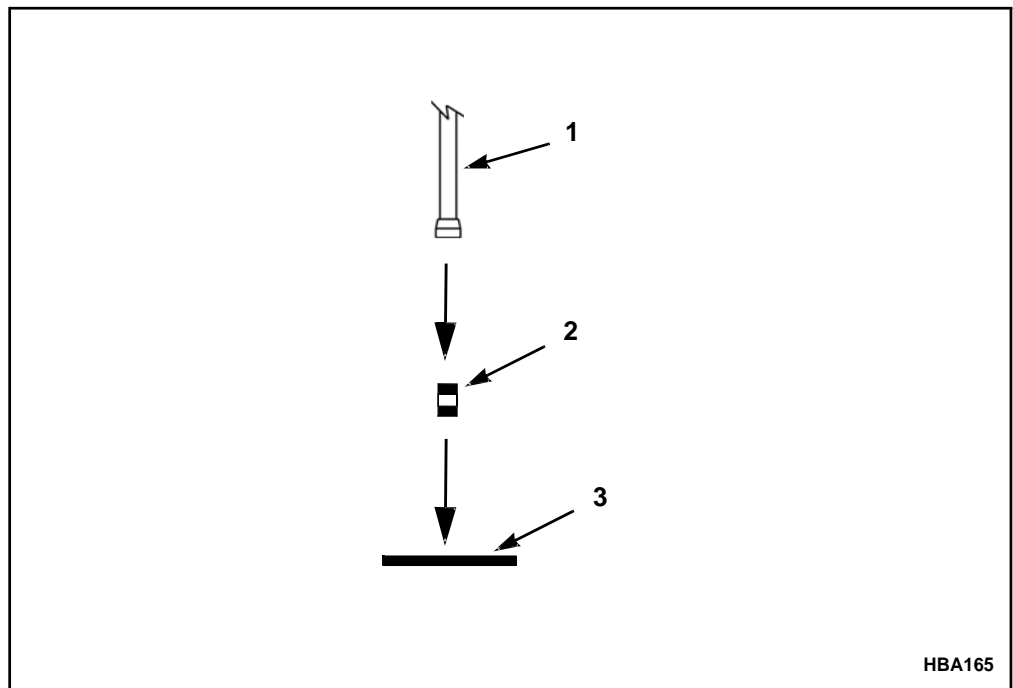

HBA165

Figure 19. Attaching the Pole

1.	Pole
2.	Frangible Coupling
3.	Baseplate

Wiring the Lights to the Power Source

After the pole has been assembled to the baseplate, wire the lights to the power source and test them. See “Wiring Diagrams” on page 43.

If all lights illuminate and appear to be in working order you can then attach the pole to the base can, see the following procedure.

Attach the Pole Assembly to the Base Can

To attach the completed pole assembly to the base can grasp the pole assembly near the bottom of the basket and stand the pole assembly upright. Move the baseplate on top of the base can and bolt in place.

CHAPTER 7

Maintaining and Servicing the Wind Cones

NOTE: Always perform maintenance based on frequency as established by airport policies and procedures and by FAA Advisory Circular AC 150/5340-26.

Tools Required

Tools needed to service the L-807 and L-806 Wind Cones are listed in “Tools and Supplies Needed” on page 17.

Lowering the Top of the L-807 Pole

To perform maintenance on the top half of the L-807 pole you must lower it nearer to the ground. This is done by performing the following steps.

1. Remove the four hinge bolts from the hinge at the center of the pole, see Figure 20 on page 38.
2. Using the winch slowly crank the pole down. Lower the pole to an easy working height, see Figure 20 on page 38.



CAUTION: Do not support the pole on the basket. Use a sawhorse, or other suitable support.

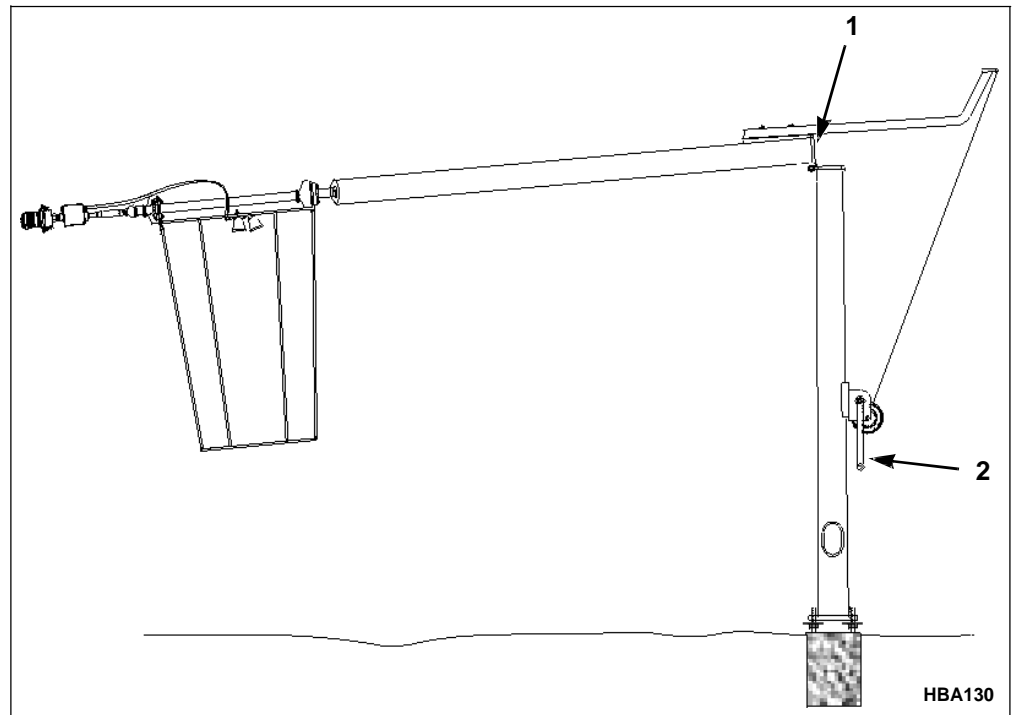

Figure 20. Lowering the Basket

1.	Hinge bolts (4)
2.	Winch handle

Inspecting Wind Cone Components

The following tables list the inspections that must be performed on a regular basis.

TABLE 2. Daily Maintenance Recommendations

Component	Action
Check lamps for operation.	Replace faulty lamps. Always clean globes inside and outside when replacing lamps.

TABLE 3. Monthly Maintenance Recommendations

Component	Action
Check wind sock for frayed edges.	Replace if torn.
Check pole for cracks.	Replace cracked pole.
Check structure for bird nests or insect problems.	Remove from structure.
Check for paint damage.	Apply touch-up paint as required.
Check wind sock for missing cable straps.	Replace missing or worn cable straps.

TABLE 3. Monthly Maintenance Recommendations (Continued)

Component	Action
Check lights for dirty lenses.	Clean with a soft damp cloth.
Check base of pole for excessive vegetation growth.	Remove vegetation.
Check winch cable for fraying or corrosion (L-807 Only).	Replace if needed.

TABLE 4. Semi-Annual Maintenance Recommendations

Component	Action
Check wiring for cracked insulation.	Call a qualified electrician, repair as necessary.
Check wind sock for missing eyelets.	Replace sock.
Check wind sock for fading.	Replace sock.
Make an insulation reading and compare results with standards and previous readings.	Replace if needed.
Check winch for proper operation.	Replace if inoperative.
Check bearing lubrication	Lubricate basket bearings

Replacing Lamps

The following table lists the halogen replacement lamps. **All models with LED lamps have a rated lamp life of 50,000 hours. All LED lamps are repaired by replacing the entire housing assembly. Contact Hali-Brite® for LED lamp replacements.**

NOTE: If a lamp has burned out always replace all of the lamps at the same time. This will reduce maintenance costs.

TABLE 5. Halogen Replacement Lamps

Power	Replacement Lamp	Rated Lamp Life
	Obstruction Light	
120 Volt	116 W, TS 120 V	8000 hrs
	Internal Flood Light	
120 Volt	Halogen 100 W, 120 V	2000 hrs
	External Flood Light	
120 Volt	Halogen 75W PAR16	2000 hrs

NOTE: See Table 6 on page 42 for part number information.

Replacing a 120 VAC Internal Halogen Lamp

1. Remove the lamp cover by twisting it counterclockwise.
2. Remove the lamp from the socket.
3. Using a glove, push a new lamp back into the socket.



CAUTION: Do not touch the lamp glass with fingers. Oil on skin may shorten the life of the lamp.

4. Replace the lamp cover.

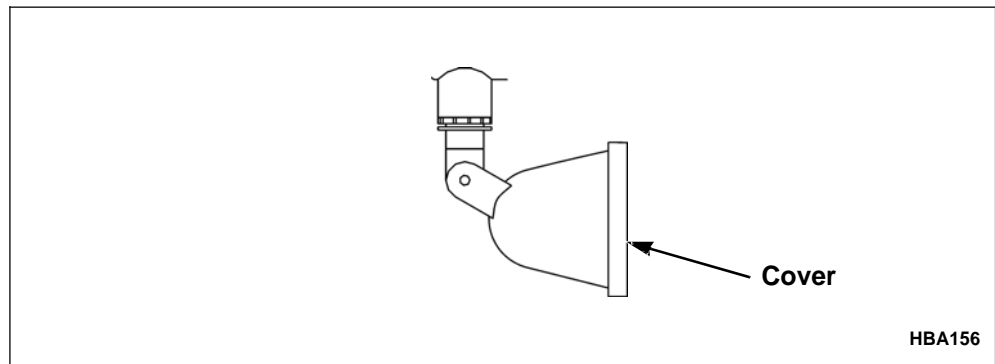

Figure 21. Replacing Internal Halogen Lamps

Replacing a 120 VAC External Halogen Lamp

1. Loosen the retaining screw on the bottom of the lamp housing.
2. Pull off the Lamp Housing Cover.
3. Unscrew the old lamp and install the replacement.
4. Install the Lamp Housing Cover and tighten the retaining screw.

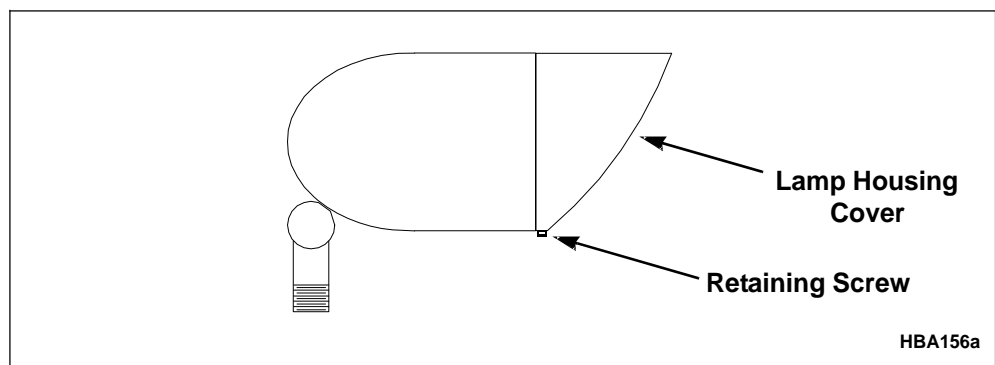

Figure 22. Replacing 120 VAC External Halogen Lamps

Replacing a Halogen Obstruction Lamp

1. Release the two clasps that attach the red lens to the light housing.
2. Remove the old lamp.
3. Using a glove, install a new lamp into the lamp socket.



CAUTION: Do not touch the lamp glass with fingers. Oil on skin may shorten the life of the lamp.

4. Replace the lens.

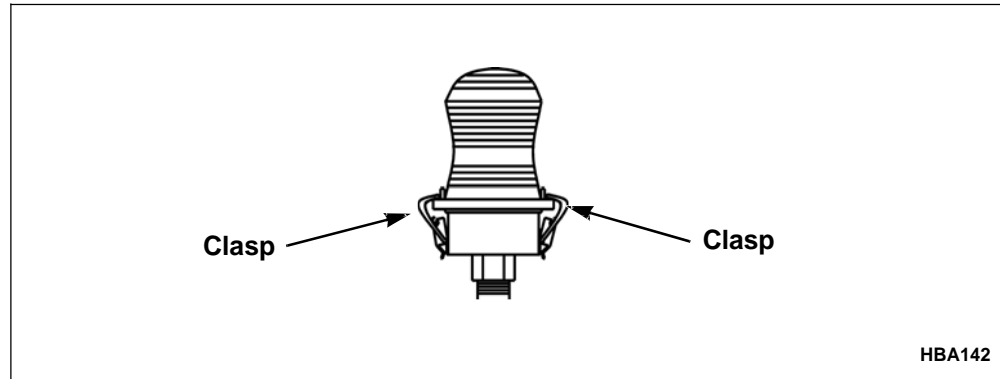

Figure 23. Removing the Obstruction Light Cover

CHAPTER 8

Spare Parts

How to Order Parts

Spare or replacement parts can be ordered by:

- Calling Hali-Brite® at 1-800-553-6269.
- Faxing your order to us at 1-218-546-6854.

Recommended Spare Parts

TABLE 6. Recommended Spare Parts List for L-806 and L-807

Description	Part Number	Quantity
Lamp, 120 V External Halogen	3400-0122	2
Lamp, 120 V Internal Halogen	3400-0100Regent	3
Lamp, 120 V Halogen Obstruction Light	3400-116TS120	1
Wind Sock, 36" x 12', Orange Nylon	7400-0002	1
Wind Sock, 18" x 8', Orange Nylon	7400-0000-1	1
L806 Frangible Coupling	1800-0025	1
Lens, L810 Halogen Obstruction Light	2700-0004	1

CHAPTER 9

Wiring Diagrams

The following wiring diagrams are for the internal and external lights on the L-806 or L-807 Wind Cone. Refer to the following table to locate the correct figure.

Type	Socket Diameter	Light Type	Power	Wiring Diagram
L-806	18"	External Halogen	120 VAC	Figure 26 on page 46
L-806	18"	External LED	12 VDC	Figure 27 on page 47
L-806	18"	External LED	120 VAC	Figure 28 on page 48
L-806	18"	External LED	6.6 Amp	Figure 31 on page 51
L-806	18"	Internal Halogen	120 VAC	Figure 25 on page 45
L-806	18"	Internal LED	120 VAC	Figure 29 on page 49
L-806	18"	Internal LED	6.6 Amp	Figure 31 on page 51
L-806	18"	External LED	230 VAC	Figure 28 on page 48
L-806	18"	Internal LED	12 VDC	Figure 27 on page 47
L-807	18"	External Halogen	120 VAC	Figure 26 on page 46
L-807	18"	External LED	12 VDC	Figure 27 on page 47
L-807	18"	External LED	120 VAC	Figure 28 on page 48
L-807	18"	External LED	6.6 Amp	Figure 31 on page 51
L-807	18"	Internal Halogen	120 VAC	Figure 25 on page 45
L-807	18"	Internal LED	120 VAC	Figure 29 on page 49
L-807	18"	Internal LED	6.6 Amp	Figure 31 on page 51
L-807	18"	External LED	230 VAC	Figure 28 on page 48
L-807	18"	Internal LED	12 VDC	Figure 27 on page 47
L-807	36"	External Halogen	120 VAC	Figure 26 on page 46
L-807	36"	External LED	12 VDC	Figure 27 on page 47
L-807	36"	External LED	120 VAC	Figure 28 on page 48
L-807	36"	External LED	6.6 Amp	Figure 31 on page 51
L-807	36"	Internal Halogen	120 VAC	Figure 24 on page 44
L-807	36"	Internal LED	120 VAC	Figure 30 on page 50
L-807	36"	Internal LED	6.6 Amp	Figure 31 on page 51
L-807	18"	External LED	230 VAC	Figure 28 on page 48
L-807	18"	Internal LED	12 VDC	Figure 27 on page 47

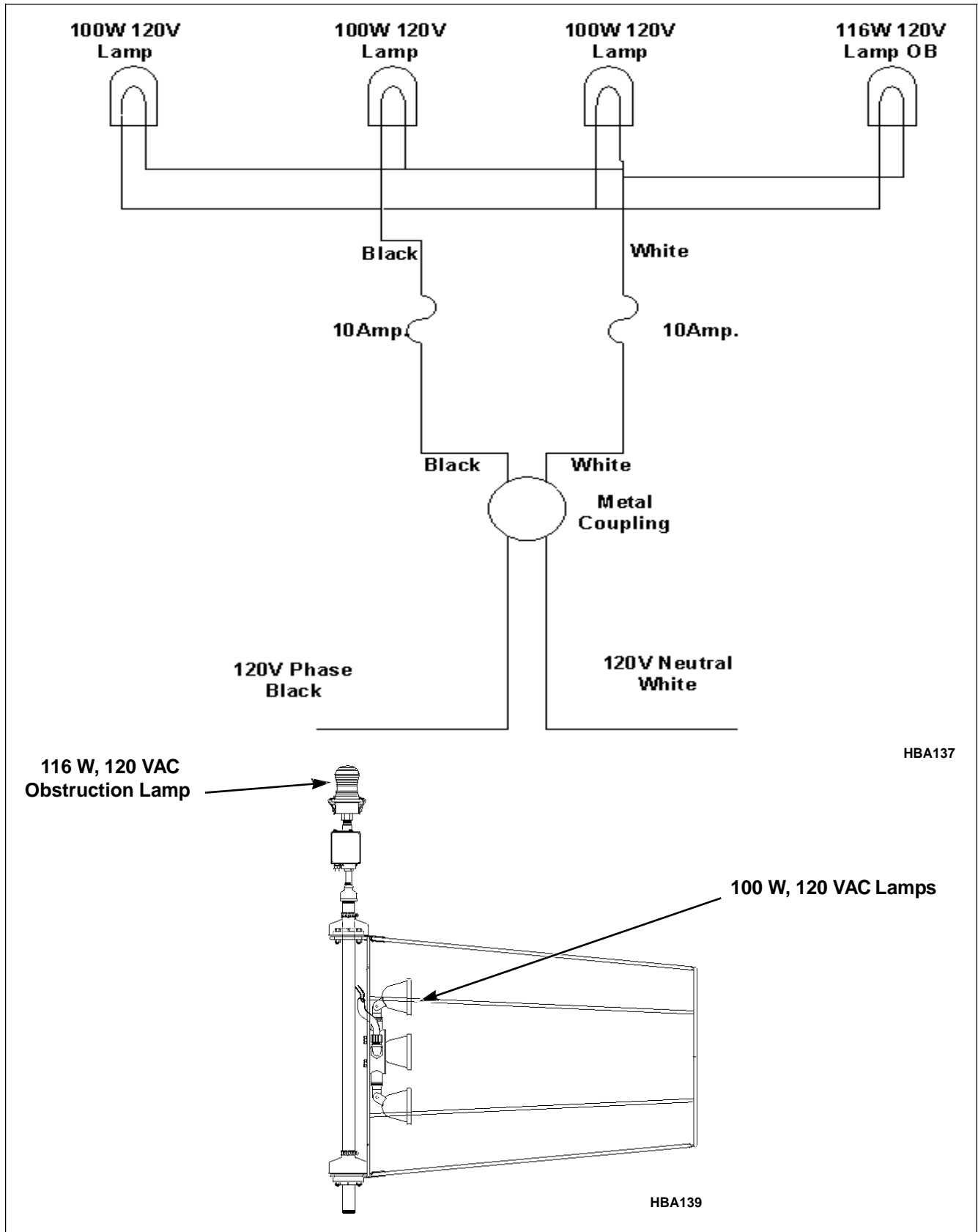

HBA137

HBA139

Figure 24. 120 VAC 36" Internal Halogen Wind Cone Light

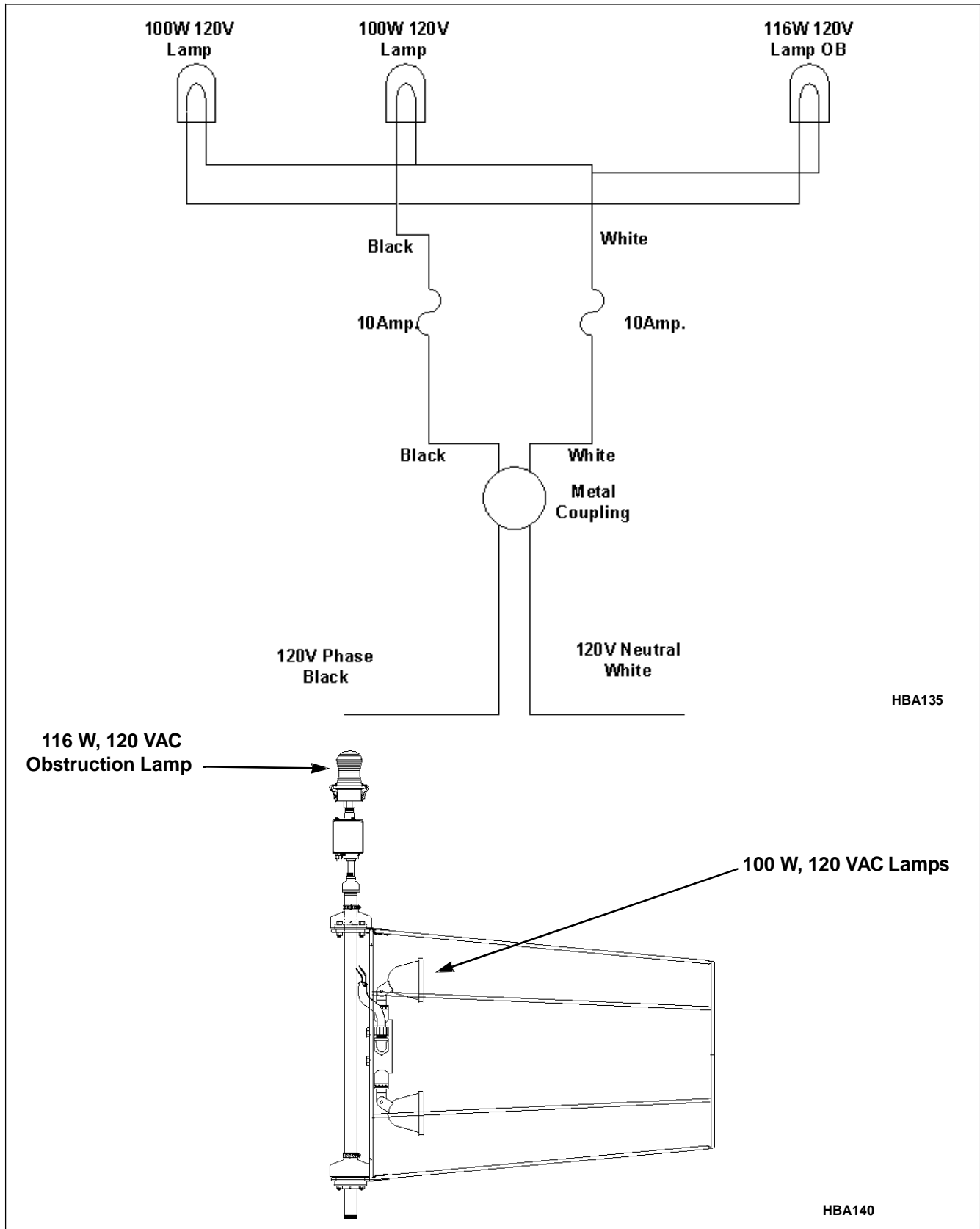

Figure 25. 120 VAC 18" Internal Halogen Wind Cone Light

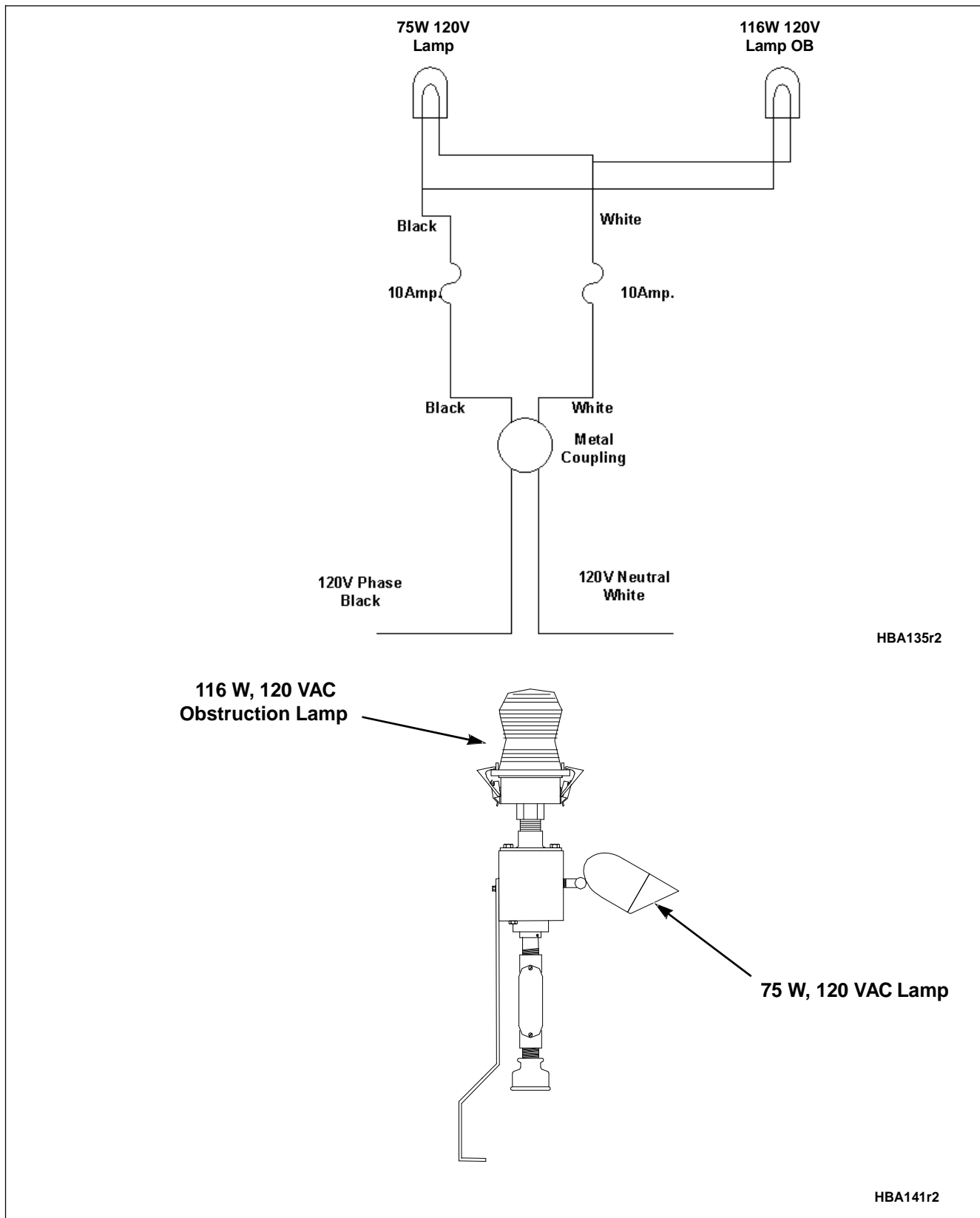

Figure 26. 120 VAC 18" or 36" External Halogen Light

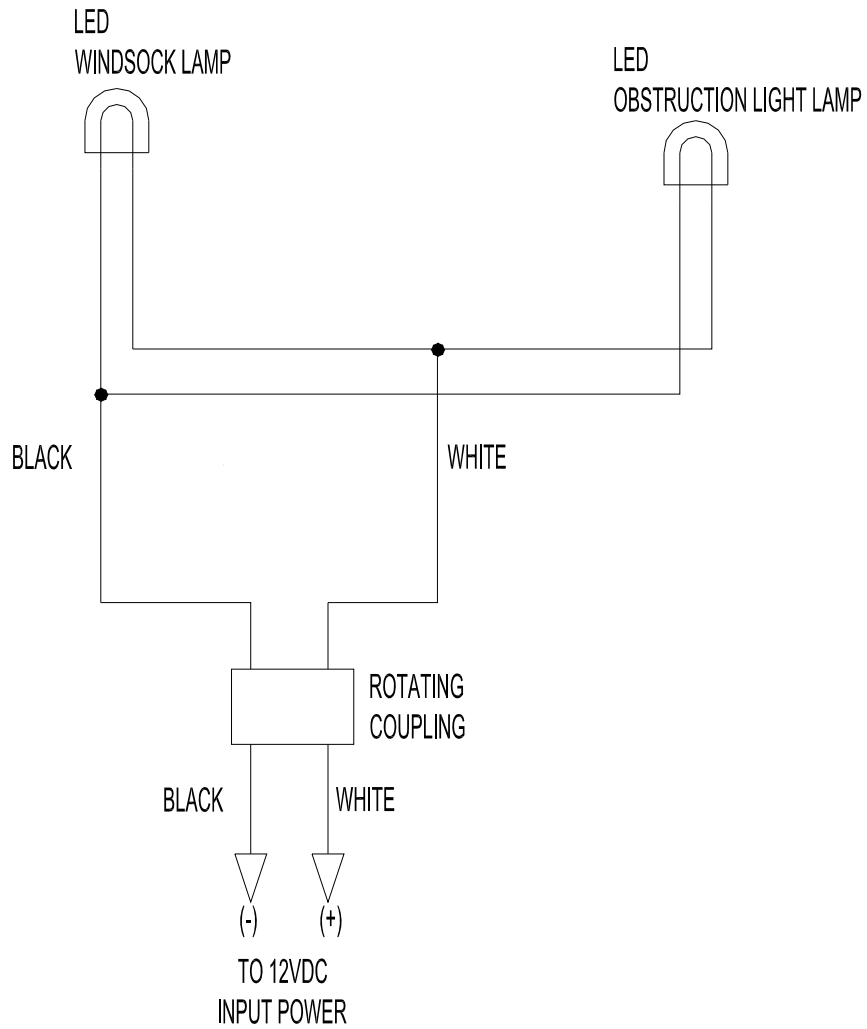

Figure 27. 12 VDC External and Internal LED Light

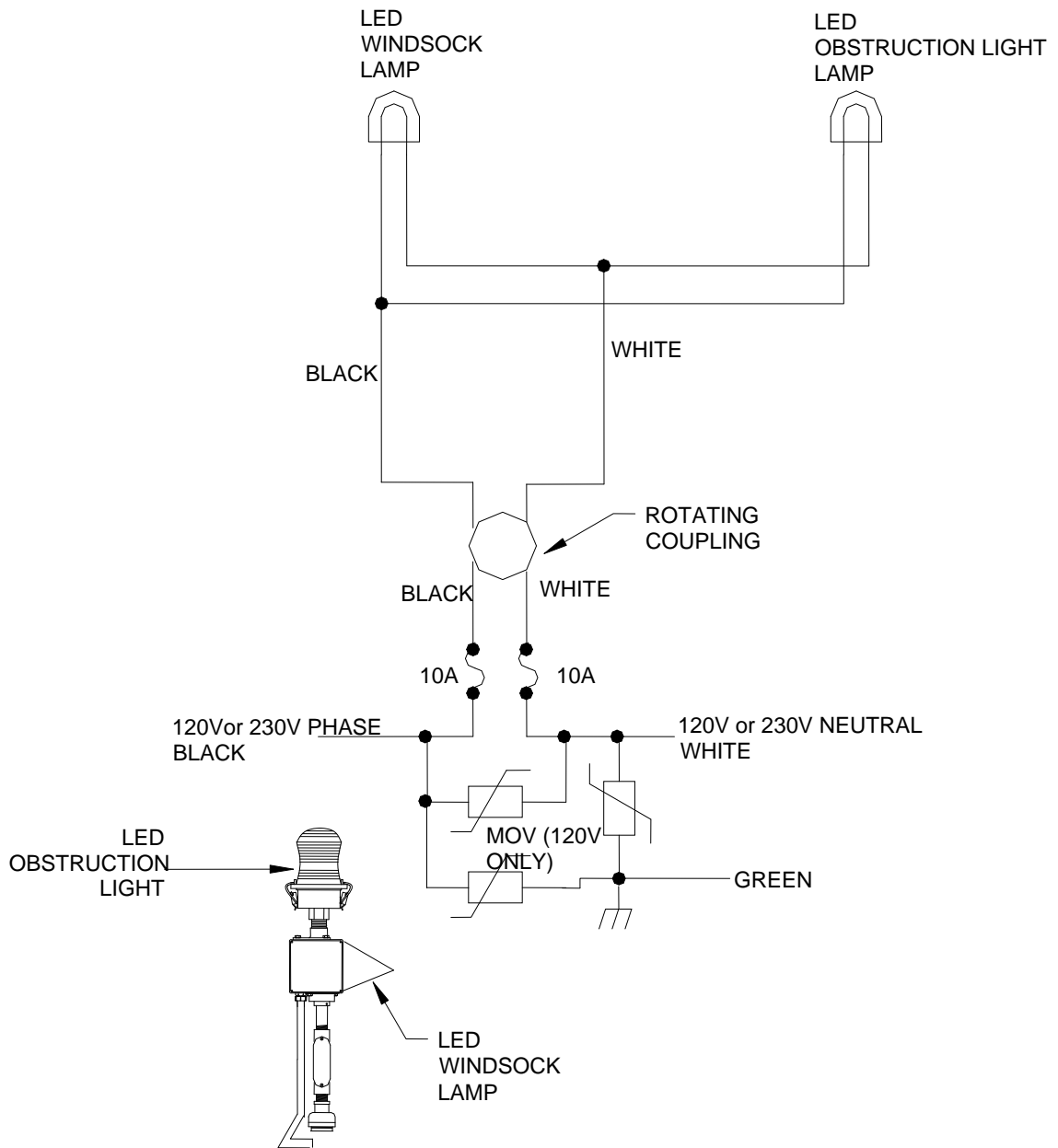

Figure 28. 120VAC and 230VAC 18" and 36" External LED Light

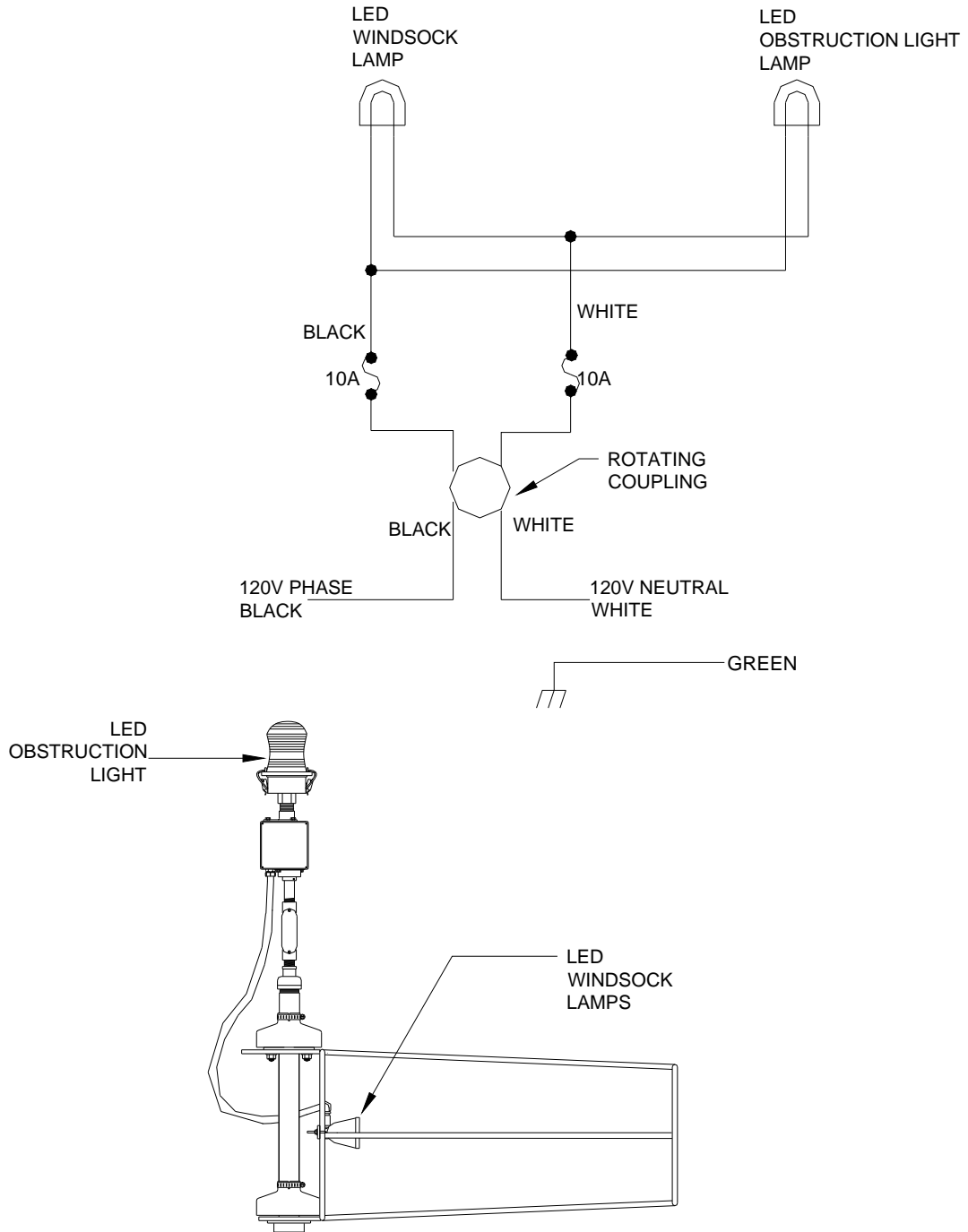

Figure 29. 120 VAC 18" Internal LED Light

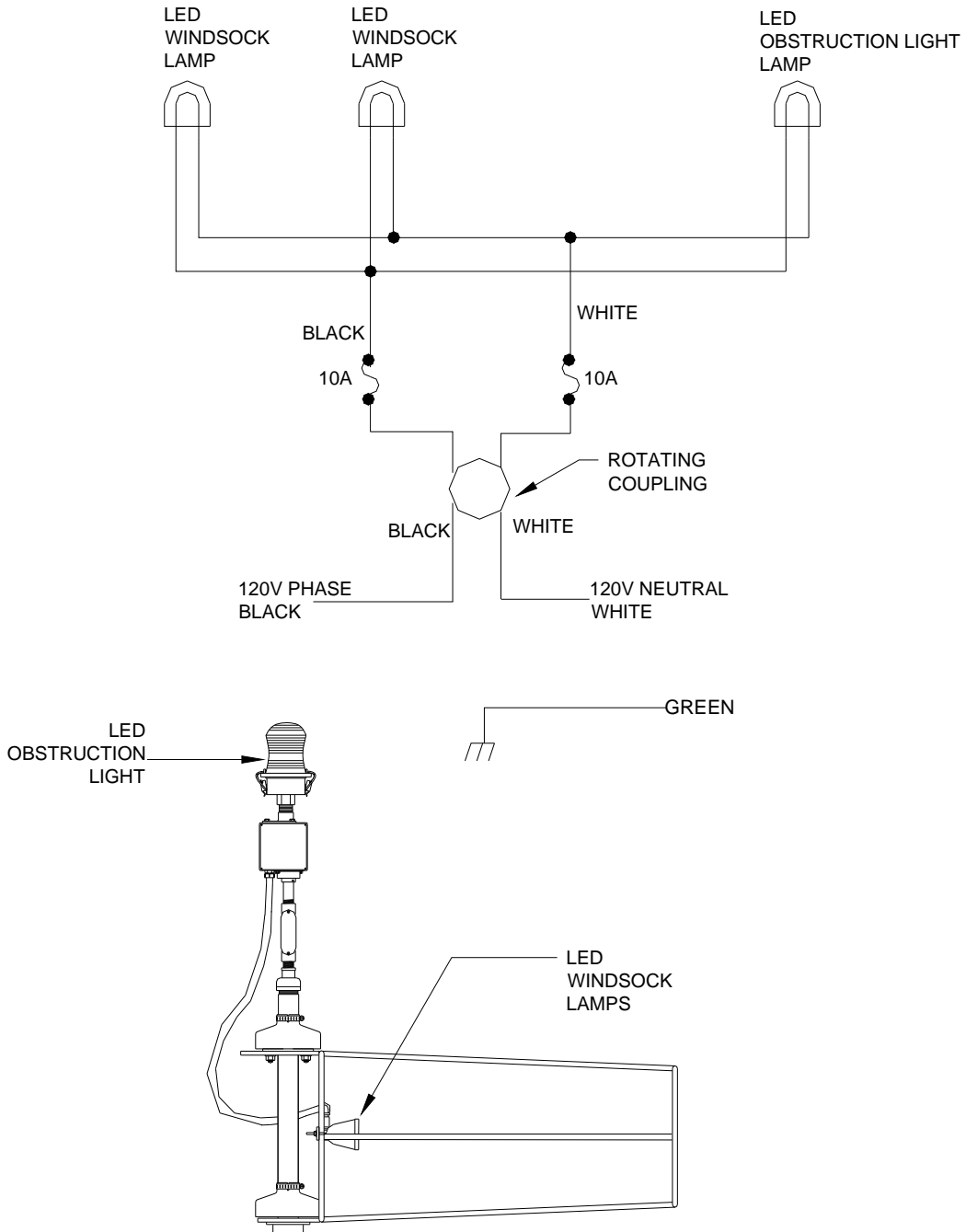

Figure 30. 120 VAC 36" Internal LED Light

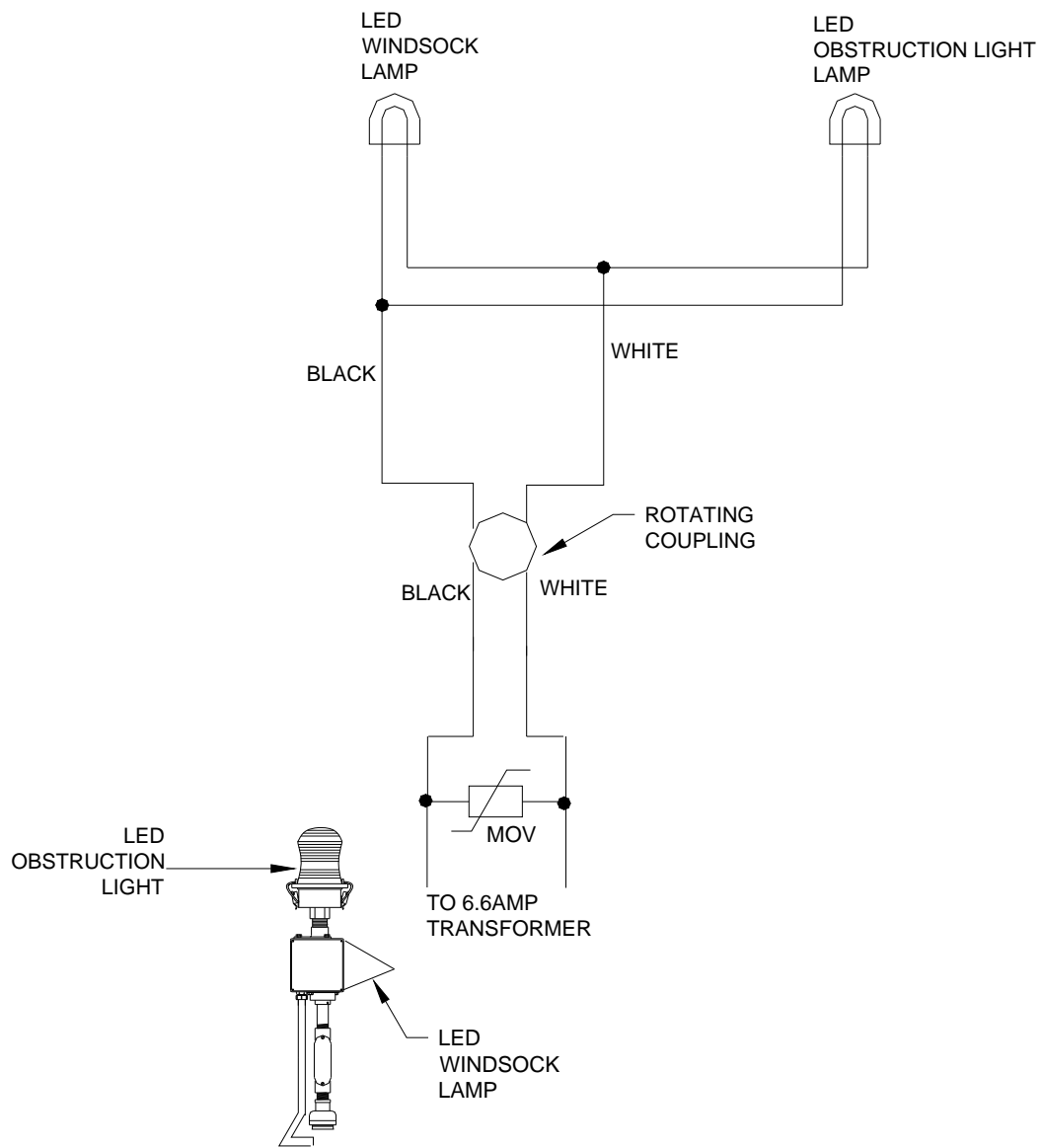

Figure 31. 6.6 Amp 18" and 36" External and Internal LED Wiring (Internal fixture not shown.)

MERCOTAC CONNECTOR RECYCLING

Thank you for returning your used Mercotac connectors for recycling and not disposing them in the trash or landfill. The used connectors will be sent to a licensed mercury recycling facility where the liquid mercury is retrieved for future use through an environmentally safe distillation process.

HOW TO RETURN MERCOTAC CONNECTORS:

Used Mercotac connectors should be returned to Mercotac Inc. by UPS Ground shipping only. Do not send Mercotac connectors through the U.S. Mail. Mercotac Inc. provides free shipping within the 48 contiguous United States. Please contact Mercotac, Inc. for these shipping instructions. The used Mercotac connectors should be shipped to:

Mercotac Inc.
Attn: Returns
6195 Corte Del Cedro
Carlsbad, CA 92011

HOW TO PACKAGE:

The Mercotac connectors should be tightly sealed in a plastic bag using twist ties or a similar closure and then packaged with cushioning in a sturdy box. This completed Recycling Form must be included in the box with the shipment.

RETURNED CONNECTORS: (PACKING LIST)

<u>Model</u>	<u>QTY.</u>	<u>Model</u>	<u>QTY.</u>
_____	_____	_____	_____
_____	_____	_____	_____
_____	_____	_____	_____
_____	_____	_____	_____
_____	_____	_____	_____

FROM:

Company: _____

Contact: _____

Address: _____

Telephone #: _____

Do you require a receipt? Y N

Fax receipt to () _____

FOR MERCOTAC USE

Received by: _____

Date received: _____

Date Faxed: _____

- 1) Verify information on form and complete above.
- 2) Place used Mercotac connectors in Recycling container.
- 3) If required Fax receipt .
- 4) File completed form in Recycle File Folder,Engineering



6195 Corte Del Cedro, Carlsbad California 92011
Telephone (760) 431-7723 • Fax (760) 431- 0905
Email: info@mercotac.com