

**MAINTENANCE DOCUMENTATION
for F30**

DOC 3802.E

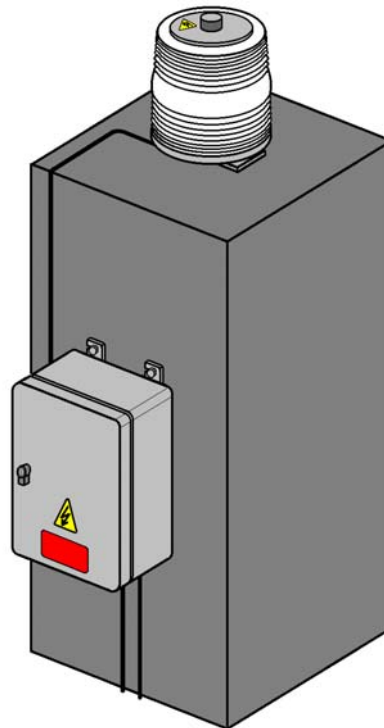

THORN

Airfield Lighting

www.thornairfield.com

THORN EUROPHANE
156 bd Haussmann
75379 Paris
Cedex 08
FRANCE
Tel : +33 (0) 1 49 53 62 62
Fax : +33 (0) 1 49 53 62 89

thornairfield@thorn.fr

Thorn DNT Airfield Lighting
7-9 Newcastle Road
Bayswater Victoria 3153
AUSTRALIA
Tel : +61 (0) 3 97 20 32 33
Fax : +61 (0) 3 97 20 82 33

enquiries@thornairfield.com

THORN LIGHTING
3 King George Close
Eastern Avenue West
Romford, Essex RM7 7PP
UNITED KINGDOM
Tel : +44 (0) 1708 776 289
Fax : +44 (0) 1708 742 322

airfield@thornlight.com

THORN CLK Airfield lighting
19/F Jardine Engineering House
260 King's Road
North point – HONG KONG
Tel : +852 (0) 2988 4128
Fax : +852 (0) 2988 4139

adminhk@thornclkaf.com.hk

RECORD of CHANGE Documentation 3802.E

Revision	Designation	Editor	Checked	Date
1	First issue	JMD		January 1998
2	Second issue with : New Logo and addresses	JMD	SD	Mai 2002
3	New issue with : Separate Installation and Maintenance	JMD	SD	September 2004

TABLE OF CONTENTS

1	INTRODUCTION	4
1.1	USE RESTRICTION NOTICE AND WARRANTY	4
1.1.1	Use of the Document	4
1.1.2	Warranty	4
1.2	SAFETY INSTRUCTIONS	5
1.3	REFERENCE DOCUMENTS	5
2	GENERAL INFORMATION AND REQUIREMENTS	6
2.1	DESCRIPTION OF THE F30	6
2.2	DESIGN OF THE F30	7
2.2.1	Flashing Head.....	8
2.2.2	Power Supply Box.....	9
2.2.3	Photocell Box (Option)	9
2.3	FUNCTIONAL DESCRIPTION	10
3	MAINTENANCE OPERATIONS.....	12
3.1	XENON FLASH TUBE VERIFICATION	12
3.1.1	Opening the flashing head.....	12
3.1.2	Clothing the flashing head.....	12
3.1.3	Verify the status of the tube	13
3.1.4	Remove the Xenon flash tube.....	13
3.1.5	Remount the Xenon flash tube.....	13
3.2	THE PROBLEM REMAIN THE SAME WITH A GOOD XENON FLASH TUBE	14

1 Introduction

The documentation lists the different steps to follow in order to successfully make the maintenance operations on the F30 Heliport Beacon.

You will find in this document two main paragraphs:

"General Information and Requirements": This chapter gives general description and use of the fitting covered by this document.

"Maintenance of F30": This chapter describes how to maintain the F30.

1.1 Use restriction notice and warranty

1.1.1 Use of the Document

This installation documentation is the property of

THORN Airfield Lighting
156 bd. Haussmann
75379 Paris Cedex 08
France

This documentation or any parts of this documentation may not be reproduced, stored in a retrieval system or transmitted in any form or by any means (mechanical, photocopying, recording, electronic,...) without THORN's prior consent.

1.1.2 Warranty

THORN Airfield Lighting guarantees that the performance of the inset lights described in this document, when sold by THORN Airfield Lighting or its licensed representatives, meets the requirements of ICAO Annex 14 volume 2.

Any defect in design, material or workmanship, which may occur during proper and normal use over a period covered by the warranty stipulate in the contract, will be replaced by THORN Airfield Lighting free of charge, ex works.

Operational failure or damage resulting from lamp burnt out, improper installation is not considered a result of proper use and is beyond the scope of the warranty.

The above constitutes the limits of THORN Airfield Lighting 's liabilities concerning the equipment covered by this document.

1.2 Safety instructions

WARNING: Prior to the commencement of work all electrical services MUST be isolated from the supply and connected to earth. Full details of the work involved must be given to the Authorise Person responsible for the electrical engineering services with regard to the duration of the work, etc.. . It is a prerequisite of this type of installation that the work should be carried out by trained and experienced personnel.

1.3 Reference documents

This paper refers to following documents:

- THORN Commercial Documentation General Brochure Doc 1001.E,
- THORN F30 Commercial Documentation Doc1802.E,
- THORN F30 Installation Documentation Doc2802.E,
- Last Edition of ICAO Annex 14,

2 General information and requirements

2.1 Description of the F30

ICAO recommend the installation of an Heliport Beacon on heliport where long range visual guidance is considered necessary and not provided by other visual means or where heliport identification is difficult due to surrounding lights.

The THORN F30 Heliport Beacon is compliant with ICAO requirements.

For ICAO an Heliport Beacon must continuously emit the signal shows **Fig 1**.

The Brilliancy level of the F30 heliport beacon can be remote controlled or automatically using a Photocell Box (Optional).

Three Brilliancy levels are available : 100 %, 10 % and 3 %.

The remote control voltage = + 24 Vdc is supplied by the F30.

For the Photocell Box, the ambient light threshold for each brilliancy level are the following :

- 100 % = Ambient light over 500 lux
- 10 % = Ambient light between 250 lux and 500 lux
- 3 % = Ambient light under 250 lux

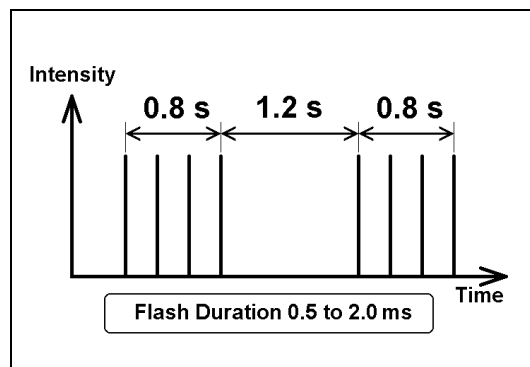

FIG 1

2.2 Design of the F30

The F30 is composed of (see Fig 2) :

- 1) One Power Supply Box (IP55)
- 2) One Flashing Head (IP55)
- 3) One Photocell Box (option)
- 4) One Power Supply Cable
 - One 2 m cable is supplied with the equipment
- 5) One special cable for Power Supply Box / Flashing Head Connection
 - One 5 m cable is supplied with the equipment. For longer length, please contact Thorn.
- 6) One cable for remote control connection by a photo-cell or by a control desk
 - One 5 m cable is supplied with the equipment.

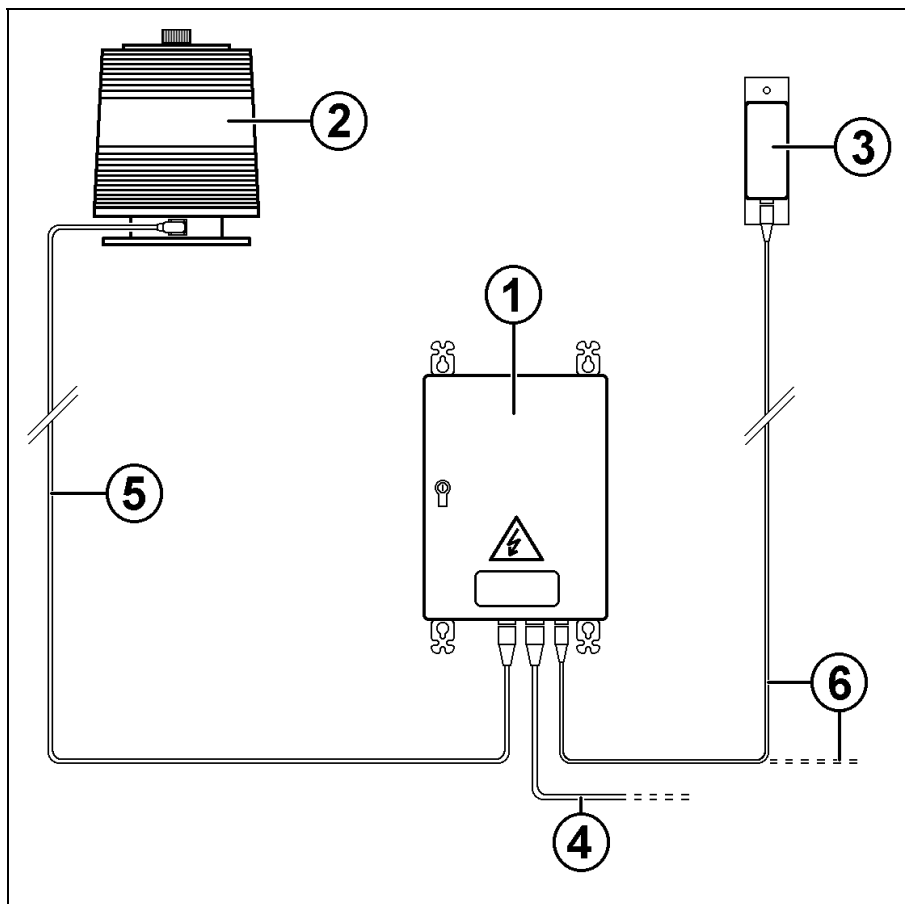

FIG 2

2.2.1 Flashing Head

The Flashing Head of the F30 contains (see Fig 3) :

- 1) Omnidirectional Fresnel White dome
- 2) Flashing base plate
- 3) F30 Xenon flash tube with reflector
- 4) Security switch
- 5) Positioning block for tube
- 6) Positioning spring for tube

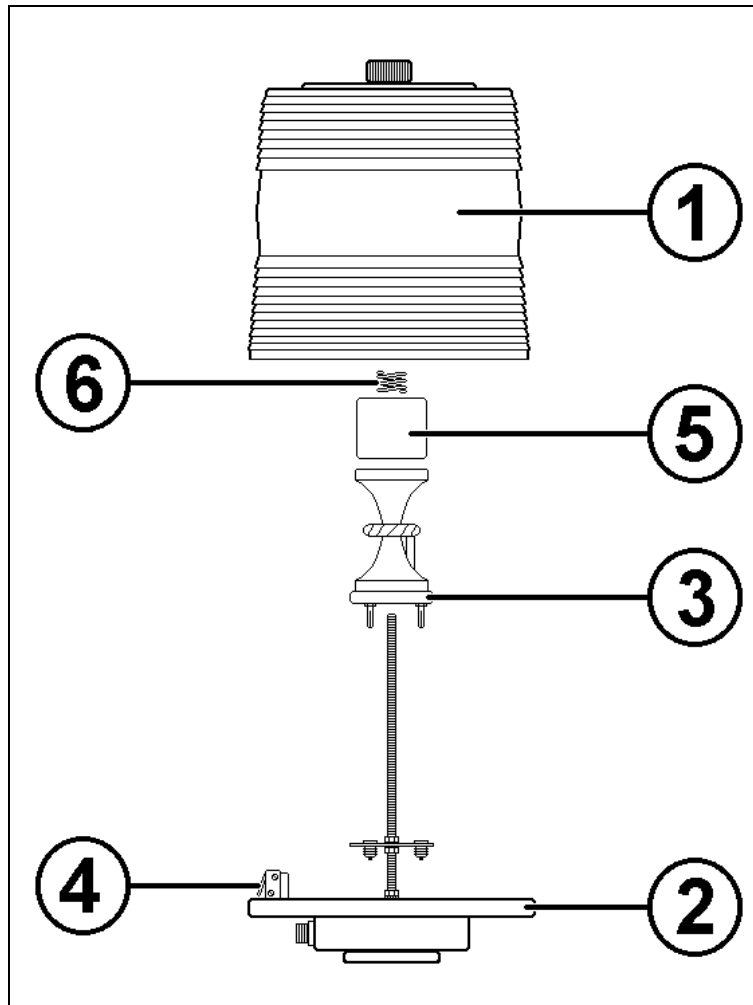

FIG 3

2.2.2 Power Supply Box

The F30 Power Supply Box contains (see Fig 4) :

- 1) High Voltage PCB
- 2) Timer PCB
- 3) Auxiliary PCB
- 4) Main Power Capacitor (150 μ F)
- 5) Auxiliary Power Capacitor (1 μ F)
- 6) Security switch

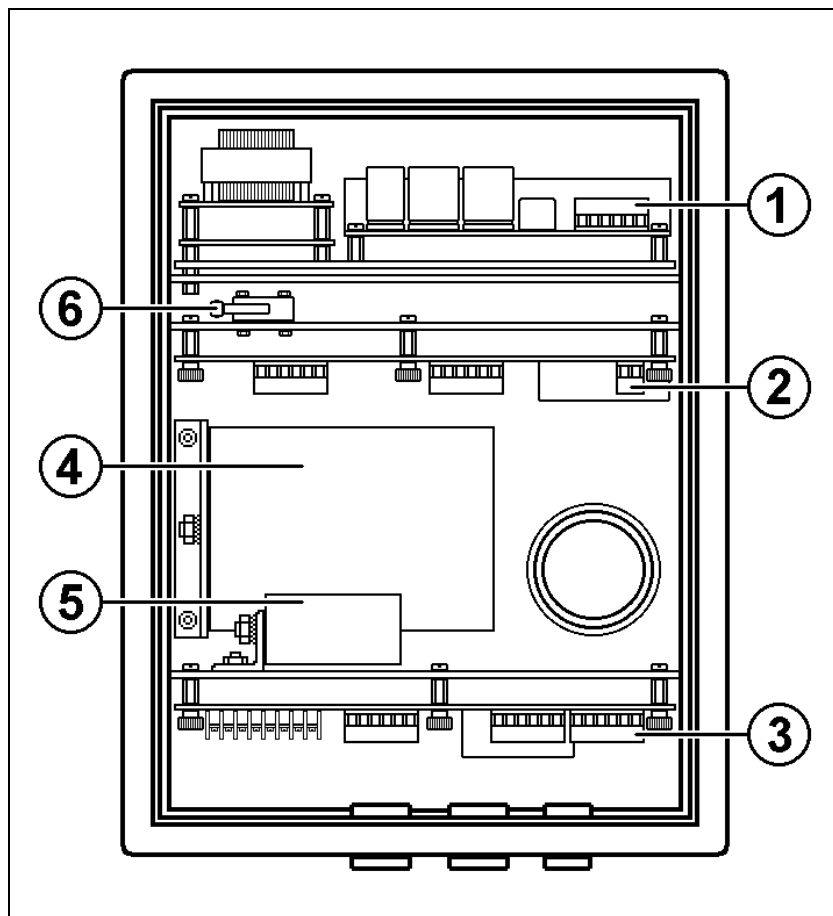

FIG 4

2.2.3 Photocell Box (Option)

The Photocell Box Contains :

- 1) A Water-tight Aluminium box.
- 2) A "Ampli and comparator" PCB.
- 3) A Silicium Photocell.
- 4) A special connecting cable.

2.3 Functional description

All the flashing light fittings are equipped with Xenon discharge bulb able to transform energy accumulated in a power capacitor in brief and intense light flash

The capacitor discharge (Flash) is triggered by ionisation of the lamp. This ionisation is obtained putting a pulse over 10 kV on the auxiliary electrode of the Xenon bulb.

For the safety of maintenance operators protection switches allow the discharge of the power capacitor (in less than 6 seconds) when an operator open the flashing head or the inside power supply box. Like this the security of the operator is effective during all direct access to internal part of the flashing unit normally under high voltage.

The Auxiliary PCB of power supply box is equipped with one small security Neon tube (See (A) Fig 8) which indicate presence of high voltage in the power supply box. Never touch internal part of the power supply box when this Neon is light on.

Nevertheless it is recommended to power off the flashing system during all operator operations.

The Power Supply Box (See **Fig 5**) includes a main 150 μ F capacitor used to store the energy required to deliver of a flash going to maximum value of 150 J. The capacitor loading high voltage is generated from a chopper supply (Chopping frequency = 30 kHz). The current shape is sine wave and the electronic power switches at zero current with very low losses and weak harmonic level. The efficiency of this operation is better than 80 % (with low level parasites).

A high voltage transformer is connected in parallel with the capacitor of the resonant circuit. A change in the load at the secondary of the transformer causes damping of the resonant circuit, therefore a reduction in output power. During the Flash, the main power capacitor is discharged into the bulb through a damping coil, which permit to limit the current value and therefore improve the bulb life duration.

Adjustment of the brilliancy level of the flashes is obtained by control of the load of the main power capacitor. This loading is linear and the stop of the loading is made when the loading voltage threshold corresponding to the brilliancy level requested is reached (see **Fig 6**).

The selection of the brilliancy level 10 % et 100 % are made using two relays, the coils of these relays are connected between the remote control entries MI or HI and GND the corresponding 0 Vdc (command in 48 Vdc). Note that without voltage the brilliancy LI = 3 % is selected.

A second chopper supply (auxiliary supply) is use to load an "Auxiliary" power capacitor which permit to trigger the flash of the bulb when the requested brilliancy level is 3 % or 10 %. In fact, in these two cases the load of the main power capacitor is not sufficient to trigger the flash in the bulb.

The good completion of the Flash is detected in the main power capacitor discharge circuit. This Flash detection permit to send back to the control room the information « the F30 flash normally ».

FIG 5 : POWER SUPPLY BOX GENERAL DESCRIPTION

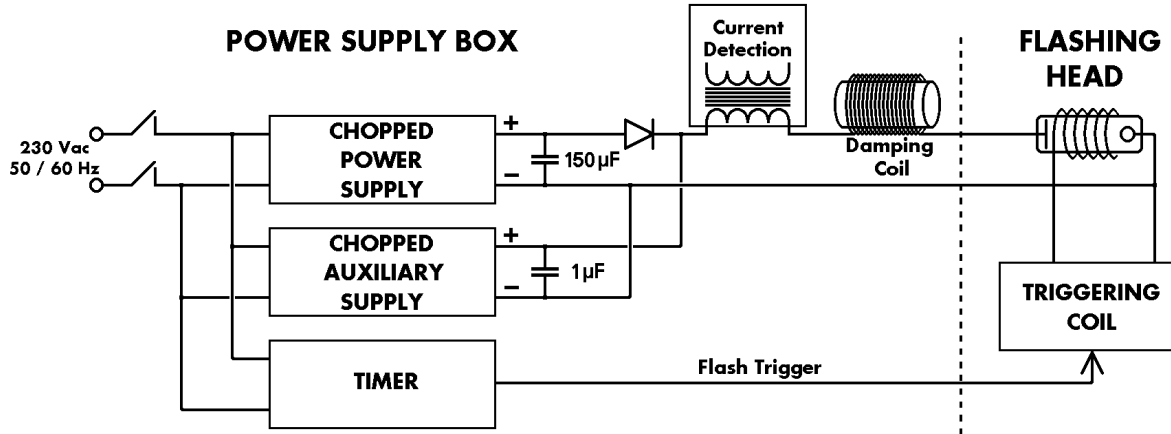
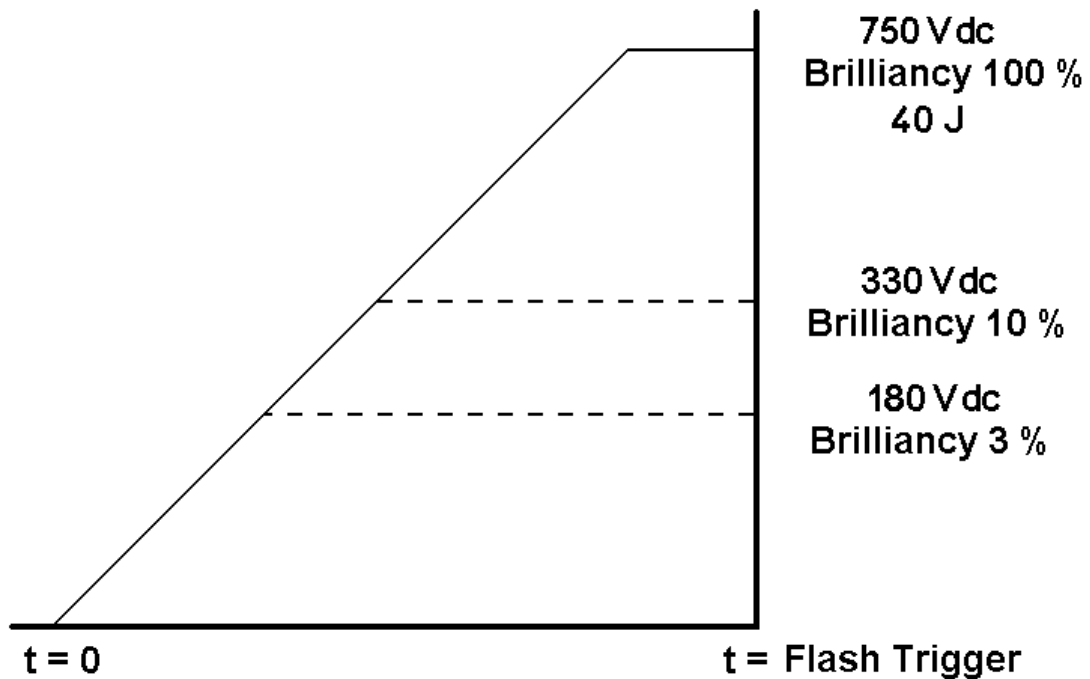

FIG 6 : LOADING OF THE MAIN POWER CAPACITOR



3 Maintenance operations

To help you in you during maintenance operations, the three drawings give in **Fig 7**, **Fig 8** and **Fig 9** show respectively the three PCB of the F30 power supply box : **Timer PCB**, **Auxiliary PCB** and **High Voltage PCB**.

Before any maintenance operation, we must verify that the F30 is power off.

When a failure occur, the first operation to do is check the cabling (see **Installation Documentation for F30**). The second operation to do is to verify the status of the Xenon flash tube.

3.1 Xenon flash tube verification

3.1.1 Opening the flashing head

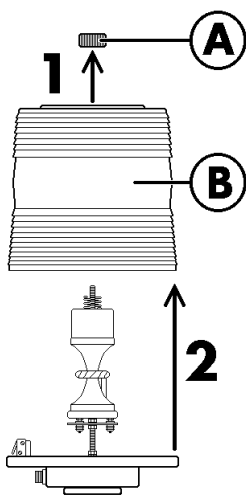

A) Unscrew and remove the fixation screw (A).

B) Remove the Fresnel dome (B) from F30 flashing base plate.

3.1.2 Clothing the flashing head

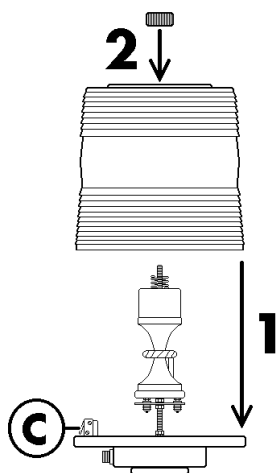

A) Mount the Fresnel dome on the 30 flashing base plate.

Note : If the dome is damage, a new dome must be installed on the flashing head.

B) Verify that the security switch (C) is activated.

C) Mount and screw the fixation screw.

3.1.3 Verify the status of the tube

Make a visual inspection of the Xenon flash tube. Th tube must be change, if the tube of black marks, or if the glass is no more transparent.

3.1.4 Remove the Xenon flash tube

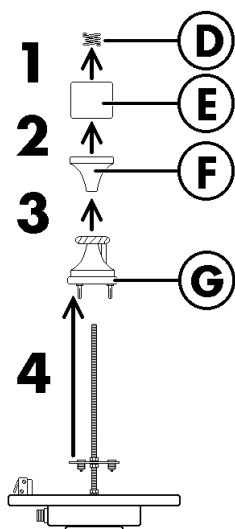

A) Open the flashing head, see **Paragraph 3.1.1**.

B) Remove the positioning spring for tube (D).

C) Remove the positioning block for tube (E).

D) Remove the upper part of the reflector (F).

E) Unplug et remove the Xenon flash tube (G).

3.1.5 Remount the Xenon flash tube

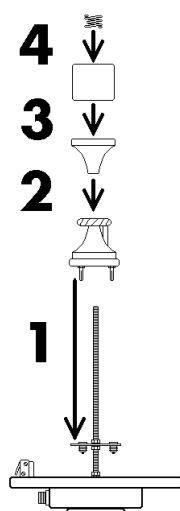

A) Mount and plug the Xenon flash tube.

Note : As the three connections are not at 120°, only possibility exist for the connection (mistake is impossible).

B) Mount the upper part of the reflector.

C) Mount the positioning block for tube.

D) Mount the positioning spring for tube.

E) Close the flashing head, see **Paragraph 3.1.2**.

3.2 The problem remain the same with a good Xenon flash tube

1) Open the power supply box (see **Fig 4**).

2) Control the Timer PCB (see **Fig 7**).

The display LED of the Timer PCB (see **(A) Fig 7**) must blink at the rythme of the flash of the F30. If the LED does not blink.

a) Verify that the F30 is correctly powered supply.

b) Check the fuse (see **(B) Fig 7**) of the Timer PCB. If the fuse is broken, change the fuse of the Timer PCB.

c) Change the Timer PCB.

3) If the Timer PCB is OK, check the fuse (see **(B) Fig 8**) of the Auxiliary PCB.

a) The fuse is broken.

I) We have a problem with the High Voltage PCB (see **Fig 9**).

II) Change the High Voltage PCB.

b) The fuse is OK.

I) Unplug the six points terminal (see **(A) Fig 9**) of the High Voltage PCB.

II) Power on the F30

III) Push on the security switch (see **(6) Fig 4**) of the power supply box.

IV) Verify that the F30 flash weakly and that the small security Neon tube (see **(A) Fig 8**) of the Auxiliary PCB is light on.

V) If it is not the case, Power off the F30 and change the Auxiliary PCB.

4) The F30 power off, check the capacitance of the power capacitors (see **(4 and 5) Fig 4**) with a capacimeter. If the capacitance of one of the capacitors does not correspond with the capacitance write on its marking, change the capacitor.

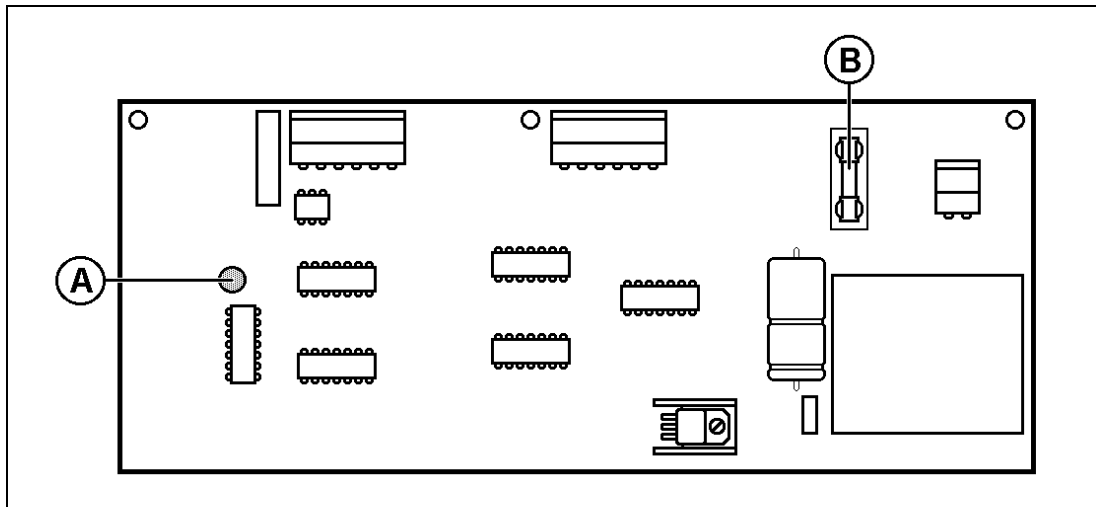

FIG 7 : TIMER PCB

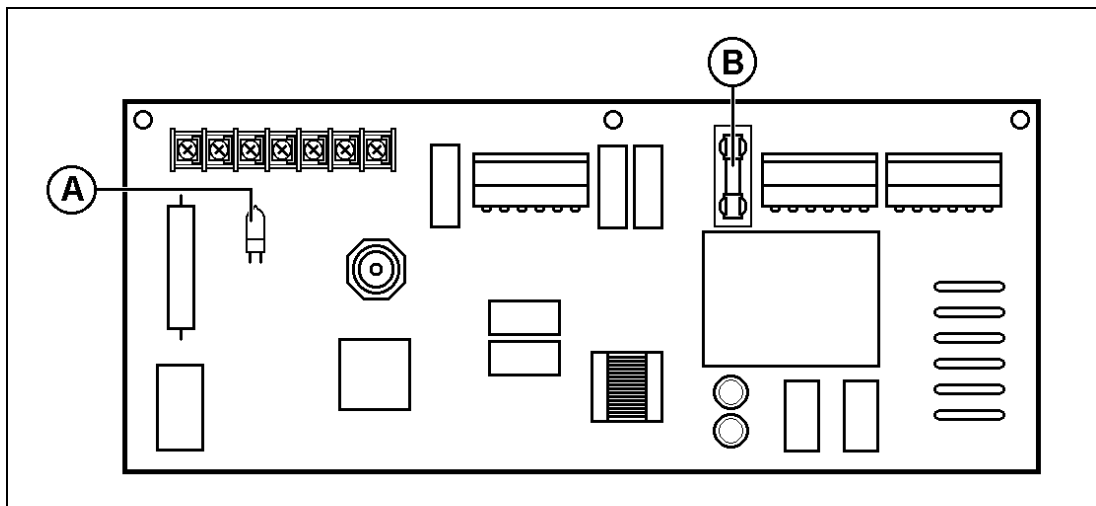

FIG 8 : AUXILIARY PCB

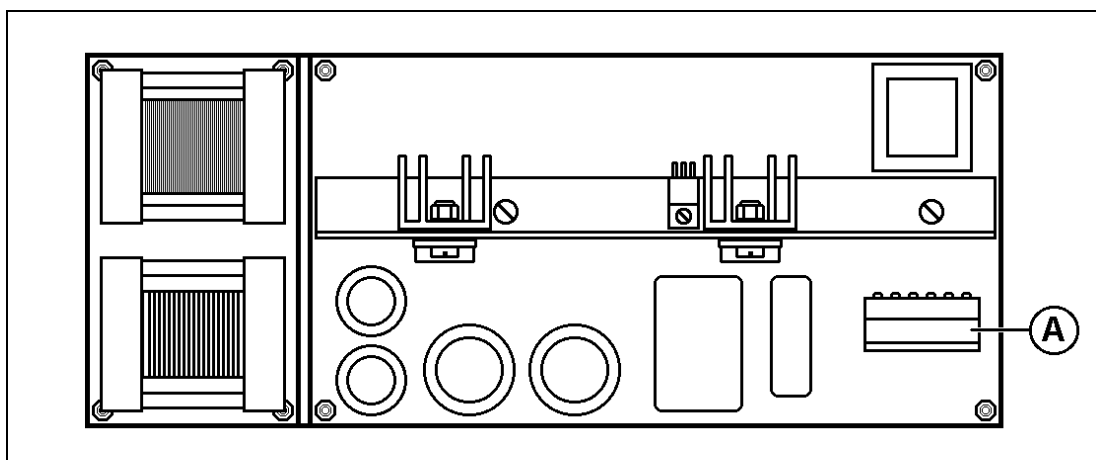

FIG 9 : HIGH VOLTAGE PCB

COMMENTS

Last page left blank for user comments.